



## Computer Science and Engineering - 2005

### Full Paper

---

1. What does the following C-statement declare?

```
int (*f) (int *) ;
```

- 1) A function that takes an integer pointer as argument and returns an integer
- 2) A function that takes an integer as argument and returns an integer pointer
- 3) A pointer to a function that takes an integer pointer as argument and returns an integer
- 4) A function that takes an integer pointer as argument and returns a function pointer

2. An Abstract Data Type (ADT) is

- 1) same as an abstract class
- 2) a data type that cannot be instantiated
- 3) a data type for which only the operations defined on it can be used, but none else
- 4) all of the above

3. A common property of logic programming languages and functional languages is

- 1) both are procedural languages
- 2) both are based on  $\lambda$ -calculus
- 3) both are declarative
- 4) both use Horn-clauses

4. Which one of the following are essential features of an object-oriented programming language?

- (i) Abstraction and encapsulation
- (ii) Strictly-typedness
- (iii) Type-safe property coupled with sub-type rule
- (iv) Polymorphism in the presence of inheritance

- 1) (i) and (ii) only
- 2) (i) and (iv) only
- 3) (i), (ii) and (iv) only
- 4) (i), (iii) and (iv) only

5. A program P reads in 500 integers in the range (0, 100) representing the scores of 500 students. It then prints the frequency of each score above 50. What would be the best way for P to store the frequencies?

- 1) An array of 50 numbers
- 2) An array of 100 numbers
- 3) An array of 500 numbers

- 4) A dynamically allocated array of 550 numbers
6. An undirected graph  $G$  has  $n$  nodes. Its adjacency matrix is given by an  $n \times n$  square matrix whose
- diagonal elements are 0's, and
  - non-diagonal elements are 1's.
- Which one of the following is TRUE?
- Graph  $G$  has no minimum spanning tree (MST)
  - Graph  $G$  has a unique MST of cost  $n-1$
  - Graph  $G$  has multiple distinct MSTs, each of cost  $n-1$
  - Graph  $G$  has multiple spanning trees of different costs
7. The time complexity of computing the transitive closure of a binary relation on a set of  $n$  elements is known to be
- $O(n)$
  - $O(n \log n)$
  - $O(n^{3/2})$
  - $O(n^3)$
8. Let  $A$ ,  $B$  and  $C$  be non-empty sets and let  $X = (A - B) - C$  and  $Y = (A - C) - (B - C)$ . Which one of the following is TRUE?
- $X = Y$
  - $X \subset Y$
  - $Y \subset X$
  - none of these

9. The following is the Hasse diagram of the poset  $[\{a, b, c, d, e\}, \leq]$

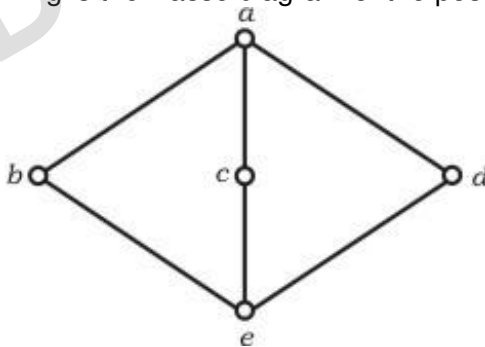

The poset is

- not a lattice
  - a lattice but not a distributive lattice
  - a distributive lattice but not a Boolean algebra
  - a Boolean algebra
10. Let  $G$  be a simple connected planar graph with 13 vertices and 19 edges. Then, the

number of faces in the planar embedding of the graph is

- 1) 6                                      2) 8                                      3) 9                                      4) 13

11. Let  $G$  be a simple graph with 20 vertices and 100 edges. The size of the minimum vertex cover of  $G$  is 8. Then, the size of the maximum independent set of  $G$  is

- 1) 12  
2) 8  
3) Less than 8  
4) More than 12

12. Let  $f(x)$  be the continuous probability density function of a random variable  $X$ . The probability that  $a < X \leq b$ , is

- 1)  $f(b - a)$   
2)  $f(b) - f(a)$   
3)  $\int_a^b f(x) dx$   
4)  $\int_a^b xf(x) dx$

13. The set  $\{1, 2, 4, 7, 8, 11, 13, 14\}$  is a group under multiplication modulo 15. The inverses of 4 and 7 are respectively

- 1) 3 and 13  
2) 2 and 11  
3) 4 and 13  
4) 8 and 14

14. The grammar  $A \rightarrow AA \mid (A) \mid \epsilon$  is not suitable for predictive-parsing because the grammar is

- 1) ambiguous  
2) left-recursive  
3) right-recursive  
4) an operator-grammar

15. Consider the following circuit.

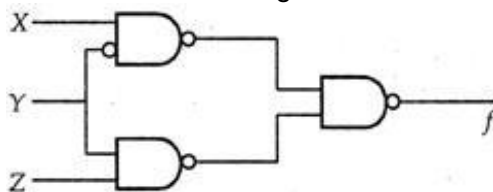

Which one of the following is TRUE?

- 1)  $f$  is independent of  $X$

- 2) f is independent of Y  
3) f is independent of Z  
4) None of X, Y, Z is redundant
16. The range of integers that can be represented by an n bit 2's complement number system is
- 1)  $-2^{n-1}$  to  $(2^{n-1} - 1)$   
2)  $-(2^{n-1} - 1)$  to  $(2^{n-1} - 1)$   
3)  $-2^{n-1}$  to  $2^{n-1}$   
4)  $-(2^{n-1} + 1)$  to  $(2^{n-1} + 1)$
17. The hexadecimal representation of  $657_8$  is
- 1) 1AF                      2) D78                      3) D71                      4) 32F
18. The switching expression corresponding to  $f(A, B, C, D) = \Sigma (1, 4, 5, 9, 11, 12)$  is
- 1)  $BC'D' + A'C'D + AB'D$   
2)  $ABC' + ACD + B'C'D$   
3)  $ACD' + A'BC' + AC'D'$   
4)  $A'BD + ACD' + BCD'$
19. Which one of the following is true for a CPU having a single interrupt request line and a single interrupt grant line?
- 1) Neither vectored interrupt nor multiple interrupting devices are possible.  
2) Vectored interrupts are not possible but multiple interrupting devices are possible.  
3) Vectored interrupts and multiple interrupting devices are both possible.  
4) Vectored interrupt is possible but multiple interrupting devices are not possible.
20. Normally user programs are prevented from handling I/O directly by I/O instructions in them. For CPUs having explicit I/O instructions, such I/O protection is ensured by having the I/O instructions privileged. In a CPU with memory mapped I/O, there is no explicit I/O instruction. Which one of the following is true for a CPU with memory mapped I/O?
- 1) I/O protection is ensured by operating system routine (s)  
2) I/O protection is ensured by a hardware trap  
3) I/O protection is ensured during system configuration  
4) I/O protection is not possible
21. What is the swap space in the disk used for?
- 1) Saving temporary html pages  
2) Saving process data  
3) Storing the super-block  
4) Storing device drivers

22. Increasing the RAM of a computer typically improves performance because
- 1) Virtual memory increases
  - 2) Larger RAMs are faster
  - 3) Fewer page faults occur
  - 4) Fewer segmentation faults occur
23. Packets of the same session may be routed through different paths in
- 1) TCP, but not UDP
  - 2) TCP and UDP
  - 3) UDP, but not TCP
  - 4) Neither TCP, nor UDP
24. The address resolution protocol (ARP) is used for
- 1) Finding the IP address from the DNS
  - 2) Finding the IP address of the default gateway
  - 3) Finding the IP address that corresponds to a MAC address
  - 4) Finding the MAC address that corresponds to an IP address
25. The maximum window size for data transmission using the selective reject protocol with n-bit frame sequence numbers is
- 1)  $2^n$
  - 2)  $2^n - 1$
  - 3)  $2^n - 1$
  - 4)  $2^n - 2$
26. In a network of LANs connected by bridges, packets are sent from one LAN to another through intermediate bridges. Since more than one path may exist between two LANs, packets may have to be routed through multiple bridges. Why is the spanning tree algorithm used for bridge-routing?
- 1) For shortest path routing between LANs
  - 2) For avoiding loops in the routing paths
  - 3) For fault tolerance
  - 4) For minimizing collisions
27. An organization has a class B network and wishes to form subnets for 64 departments. The subnet mask would be
- 1) 255.255.0.0
  - 2) 255.255.64.0
  - 3) 255.255.128.0
  - 4) 255.255.252.0
28. Which one of the following is a key factor for preferring B<sup>+</sup> -trees to binary search trees for

indexing database relations?

- 1) Database relations have a large number of records
- 2) Database relations are sorted on the primary key
- 3) B<sup>+</sup> -trees require less memory than binary search trees
- 4) Data transfer from disks is in blocks

29. Which one of the following statements about normal forms is FALSE?

- 1) BCNF is stricter than 3NF
- 2) Lossless, dependency-preserving decomposition into 3NF is always possible
- 3) Lossless, dependency-preserving decomposition into BCNF is always possible
- 4) Any relation with two attributes is in BCNF

30. Let  $r$  be a relation instance with schema  $R = (A, B, C, D)$ . We define  $r_1 = \Pi_{A, B, C}(r)$  and  $r_2 = \Pi_{A, D}(r)$ . Let  $s = r_1 * r_2$  where  $*$  denotes natural join. Given that the decomposition of  $r$  into  $r_1$  and  $r_2$  is lossy, which one of the following is TRUE?

- 1)  $s \subset r$
- 2)  $r \cup s = r$
- 3)  $r \subset s$
- 4)  $r * s = s$

31. Consider the following C-program

```
void foo (int n, int sum) {
    int k = 0, j = 0;
    if (n == 0) return;
    k = n% 10; j = n/10;
    sum = sum + k;
    foo (j, sum);
    printf ("%d", k);
}
int main ( ) {
    int a = 2048, sum = 0;
    foo (a, sum);
    printf ("%d/n", sum);
}
```

What does the above program print?

- 1) 8, 4, 0, 2, 14
- 2) 8, 4, 0, 2, 0
- 3) 2, 0, 4, 8, 14
- 4) 2, 0, 4, 8, 0

32. Consider the following C-program

```
double foo (double); /* Line 1 */
int main ( ) {
    double da, db;
    // input da
```

```

db = foo (da);
}
double foo (double a){
return a;
}

```

The above code compiled without any error or warning. If Line 1 is deleted, the above code will show

- 1) no compile warning or error
- 2) some compiler-warnings not leading to unintended results
- 3) some compiler-warnings due to type-mismatch eventually leading to unintended results
- 4) compiler errors

33. Postorder traversal of a given binary search tree T produces the following sequence of keys

10, 9, 23, 22, 27, 25, 15, 50, 95, 60, 40, 29

Which one of the following sequences of keys can be the result of an inorder traversal of the tree T?

- 1) 9, 10, 15, 22, 23, 25, 27, 29, 40, 50, 60, 95
- 2) 9, 10, 15, 22, 40, 50, 60, 95, 23, 25, 27, 29
- 3) 29, 15, 9, 10, 25, 22, 23, 27, 40, 60, 50, 95
- 4) 95, 50, 60, 40, 27, 23, 22, 25, 10, 9, 15, 29

34. A Priority-Queue is implemented as a Max-Heap. Initially, it has 5 elements. The level-order traversal of the heap is given below:

10, 8, 5, 3, 2

Two new elements '1' and '7' are inserted in the heap in that order. The level-order traversal of the heap after the insertion of the elements is

- 1) 10, 8, 7, 5, 3, 2, 1
- 2) 10, 8, 7, 2, 3, 1, 5
- 3) 10, 8, 7, 1, 2, 3, 5
- 4) 10, 8, 7, 3, 2, 1, 5

35. How, many distinct binary search trees can be created out of 4 distinct keys?

- 1) 5
- 2) 14
- 3) 24
- 4) 42

36. In a complete k-ary tree, every internal node has exactly k children. The number of leaves in such a tree with n internal nodes is

- 1) nk
- 2)  $(n - 1)k + 1$
- 3)  $n(k - 1) + 1$
- 4)  $n(k - 1)$

37. Suppose  $T(n) = 2T(n/2) + n$ ,  $T(0) = T(1) = 1$   
Which one of the following is FALSE?

- 1)  $T(n) = O(n^2)$
- 2)  $T(n) = \theta(n \log n)$
- 3)  $T(n) = \Omega(n^2)$
- 4)  $T(n) = O(n \log n)$

38. Let  $G(V, E)$  an undirected graph with positive edge weights. Dijkstra's single-source shortest path algorithm can be implemented using the binary heap data structure with time complexity:

- 1)  $O(|V|^2)$
- 2)  $O(|E| + |V| \log |V|)$
- 3)  $O(|V| \log |V|)$
- 4)  $O((|E| + |V|) \log |V|)$

39. Suppose there are  $\lceil \log n \rceil$  sorted lists of  $\lfloor n/\log n \rfloor$  elements each. The time complexity of producing a sorted list of all these elements is :

(Hint : Use a heap data structure)

- 1)  $O(n \log \log n)$
- 2)  $\theta(n \log n)$
- 3)  $\Omega(n \log n)$
- 4)  $\Omega(n^{3/2})$

40. Let  $P, Q$  and  $R$  be three atomic propositional assertions. Let  $X$  denote  $(P \vee Q) \rightarrow R$  and  $Y$  denote  $(P \rightarrow R) \vee (Q \rightarrow R)$ . Which one of the following is a tautology?

- 1)  $X \equiv Y$
- 2)  $X \rightarrow Y$
- 3)  $Y \rightarrow X$
- 4)  $\neg Y \rightarrow X$

41. What is the first order predicate calculus statement equivalent to the following?

Every teacher is liked by some student

- 1)  $\forall (x) [\text{teacher}(x) \rightarrow \exists (y) [\text{student}(y) \rightarrow \text{likes}(y, x)]]$
- 2)  $\forall (x) [\text{teacher}(x) \rightarrow \exists (y) [\text{student}(y) \wedge \text{likes}(y, x)]]$
- 3)  $\exists (y) \forall (x) [\text{teacher}(x) \rightarrow [\text{student}(y) \wedge \text{likes}(y, x)]]$
- 4)  $\forall (x) [\text{teacher}(x) \wedge \exists (y) [\text{student}(y) \rightarrow \text{likes}(y, x)]]$

42. Let  $R$  and  $S$  be any two equivalence relations on a non-empty set  $A$ . Which one of the following statements is TRUE?

- 1)  $R \cup S, R \cap S$  are both equivalence relations
- 2)  $R \cup S$  is an equivalence relation
- 3)  $R \cap S$  is an equivalence relation
- 4) Neither  $R \cup S$  nor  $R \cap S$  is an equivalence relation



43. Let  $f : B \rightarrow C$  and  $g : A \rightarrow B$  be two functions and let  $h = f \circ g$ . Given that  $h$  is an onto function. Which one of the following is TRUE?

- 1)  $f$  and  $g$  should both be onto functions.
- 2)  $f$  should be onto but  $g$  need not be onto
- 3)  $g$  should be onto but  $f$  need not be onto
- 4) both  $f$  and  $g$  need not be onto

44. What is the minimum number of ordered pairs of non-negative numbers that should be chosen to ensure that there are two pairs  $(a, b)$  and  $(c, d)$  in the chosen set such that  $a \equiv c \pmod 3$  and  $b \equiv d \pmod 5$

- 1) 4
- 2) 6
- 3) 16
- 4) 24

45. Consider three decision problems  $P_1, P_2$  and  $P_3$ . It is known that  $P_1$  is decidable and  $P_2$  is undecidable. Which one of the following is TRUE?

- 1)  $P_3$  is decidable if  $P_1$  is reducible to  $P_3$
- 2)  $P_3$  is undecidable if  $P_3$  is reducible to  $P_2$
- 3)  $P_3$  is undecidable if  $P_2$  is reducible to  $P_3$
- 4)  $P_3$  is decidable if  $P_3$  is reducible to  $P_2$ 's complement

46. Consider the set  $H$  of all  $3 \times 3$  matrices of the type

$$\begin{bmatrix} a & f & e \\ 0 & b & d \\ 0 & 0 & c \end{bmatrix}$$

where  $a, b, c, d, e$  and  $f$  are real numbers and  $abc \neq 0$ . Under the matrix multiplication operation, the set  $H$  is

- 1) a group
- 2) a monoid but not a group
- 3) a semigroup but not a monoid
- 4) neither a group nor a semigroup

47. Which one of the following graphs is NOT planar?

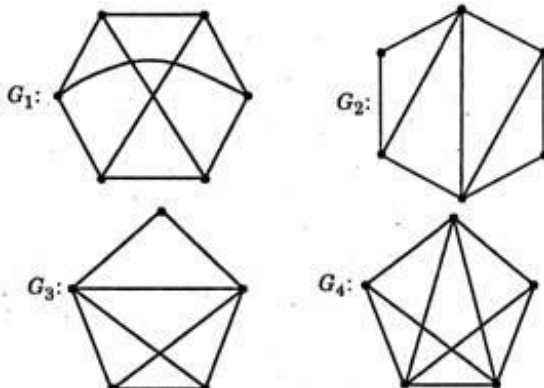

- 1)  $G_1$
- 2)  $G_2$

3)  $G_3$

4)  $G_4$

48. Consider the following system of equations in three real variables  $x_1$ ,  $x_2$  and  $x_3$

$$2x_1 - x_2 + 3x_3 = 1$$

$$3x_1 - 2x_2 + 5x_3 = 2$$

$$-x_1 + 4x_2 + x_3 = 3$$

This system of equations has

1) no solution

2) a unique solution

3) more than one but a finite number of solutions

4) an infinite number of solutions

49. What are the eigenvalues of the following  $2 \times 2$  matrix?

$$\begin{bmatrix} 2 & -1 \\ -4 & 5 \end{bmatrix}$$

1) -1 and 1

2) 1 and 6

3) 2 and 5

4) 4 and -1

50. Let  $G(x) = a/(1-x)^2 = \sum_{i=0}^{\infty} g(i)x^i$ , where  $|x| < 1$ . What is  $g(i)$  ?

1)  $i$

2)  $i + 1$

3)  $2i$

4)  $2^i$

51. Box P has 2 red balls and 3 blue balls and box Q has 3 red balls and 1 blue ball. A ball is selected as follows:

(i) select a box

(ii) choose a ball from the selected box such that each ball in the box is equally likely to be chosen. The probabilities of selecting boxes P and Q are  $(1/3)$  and  $(2/3)$ , respectively.

Given that a ball selected in the above process is a red ball, the probability that it came from the box P is

1)  $4/19$

2)  $5/19$

3)  $2/9$

4)  $19/30$

52. A random bit string of length  $n$  is constructed by tossing a fair coin  $n$  times and setting a bit to 0 or 1 depending on outcomes head and tail, respectively. The probability that two such randomly generated strings are not identical is

1)  $1/2^n$

2)  $1 - (1/2^n)$

- 3)  $(1/n)!$
- 4)  $1 - (1/2^n)$

53. Consider the machine M:

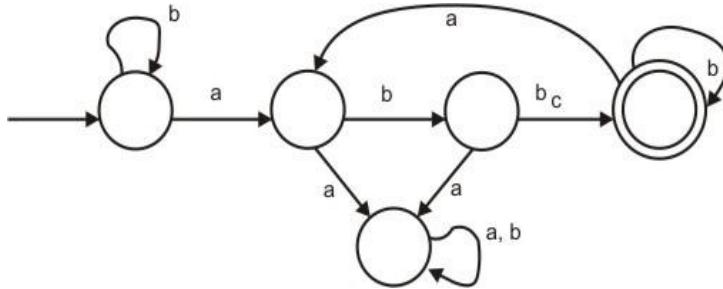

The language recognized by M is :

- 1)  $\{w \in \{a, b\}^* \mid \text{every } a \text{ in } w \text{ is followed by exactly two } b\text{'s}\}$
  - 2)  $\{w \in \{a, b\}^* \mid \text{every } a \text{ in } w \text{ is followed by at least two } b\text{'s}\}$
  - 3)  $\{w \in \{a, b\}^* \mid w \text{ contains the substring 'abb'}\}$
  - 4)  $\{w \in \{a, b\}^* \mid w \text{ does not contain 'aa' as a substring}\}$
54. Let  $N_f$  and  $N_p$  denote the classes of languages accepted by non-deterministic finite automata and non-deterministic push-down automata, respectively. Let  $D_f$  and  $D_p$  denote the classes of languages accepted by deterministic finite automata and deterministic push-down automata, respectively. Which one of the following is TRUE?
- 1)  $D_f \subset N_f$  and  $D_p \subset N_p$
  - 2)  $D_f \subset N_f$  and  $D_p = N_p$
  - 3)  $D_f = N_f$  and  $D_p = N_p$
  - 4)  $D_f = N_f$  and  $D_p \subset N_p$
55. Consider the languages  $L_1 = \{a^n b^n c^m \mid n, m > 0\}$  and  $L_2 = \{a^n b^m c^m \mid n, m > 0\}$ . Which one of the following statements is FALSE?
- 1)  $L_1 \cap L_2$  is a context-free language
  - 2)  $L_1 \cup L_2$  is a context-free language
  - 3)  $L_1$  and  $L_2$  are context-free language
  - 4)  $L_1 \cap L_2$  is a context sensitive language
56. Let  $L_1$  be a recursive language, and let  $L_2$  be a recursively enumerable but not a recursive language. Which one of the following is TRUE?
- 1)  $L_1$  is recursive and  $L_2$  is recursively enumerable
  - 2)  $L_1$  is recursive and  $L_2$  is not recursively enumerable
  - 3)  $L_1$  and  $L_2$  are recursively enumerable
  - 4)  $L_1$  is recursively enumerable and  $L_2$  is recursive

57. Consider the languages

$$L_1 = \{ww^R \mid w \in \{0, 1\}^*\}$$

$$L_2 = \{w \# w^R \mid w \in \{0, 1\}^*\}, \text{ where } \# \text{ is a special symbol}$$

$$L_3 = \{ww \mid w \in \{0, 1\}^*\}$$

Which one of the following is TRUE?

- 1)  $L_1$  is a deterministic CFL
- 2)  $L_2$  is a deterministic CFL
- 3)  $L_3$  is a CFL, but not a deterministic CFL
- 4)  $L_3$  is a deterministic CFL

58. Consider the following two problems on undirected graphs

$\alpha$  : Given  $G(V, E)$ , does  $G$  have an independent set of size  $|V| - 4$ ?

$\beta$  : Given  $G(V, E)$ , does  $G$  have an independent set of size 5?

Which one of the following is TRUE?

- 1)  $\alpha$  is in P and  $\beta$  is NP-complete
- 2)  $\alpha$  is NP-complete and  $\beta$  is in P
- 3) Both  $\alpha$  and  $\beta$  are NP-complete
- 4) Both  $\alpha$  and  $\beta$  are in P

59. Consider the grammar

$$E \rightarrow E + n \mid E \times n \mid n$$

For a sentence  $n + n \times n$ , the handles in the right-sentential form of the reduction are

- 1)  $n, E + n$  and  $E + n \times n$
- 2)  $n, E + n$  and  $E + E \times n$
- 3)  $n, n + n$  and  $n + n \times n$
- 4)  $n, E + n$  and  $E \times n$

60. Consider the grammar

$$S \rightarrow (S) \mid a$$

Let the number of states in SLR (1), LR (1) and LALR (1) parsers for the grammar be  $n_1$ ,  $n_2$  and  $n_3$  respectively. The following relationship holds good

- 1)  $n_1 < n_2 < n_3$
- 2)  $n_1 = n_3 < n_2$
- 3)  $n_1 = n_2 = n_3$
- 4)  $n_1 \geq n_3 \geq n_2$

61. Consider line number 3 of the following C- program.

```
int main ( ) {           /* Line 1 */
int I, N;                /* Line 2 */
for (I = 0, I < N, I++); /* Line 3 */
}
```

Identify the compiler's response about this line while creating the object-module

- 1) No compilation error

- 2) Only a lexical error
- 3) Only syntactic errors
- 4) Both lexical and syntactic errors

62. Consider the following circuit involving a positive edge triggered D FF.

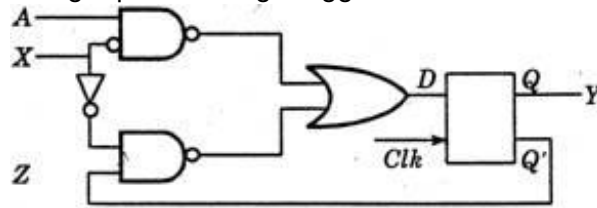

Consider the following timing diagram. Let  $A_i$  represent the logic level on the line A in the  $i$ -th clock period.

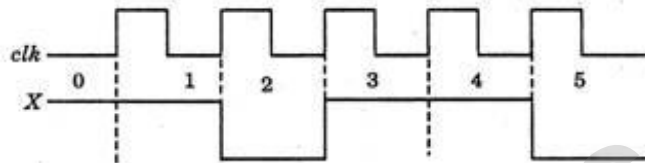

Let  $A'$  represent the complement of A. The correct output sequence on Y over the clock periods 1 through 5 is

- 1)  $A_0 A_1 A_1' A_3 A_4$
- 2)  $A_0 A_1 A_2' A_3 A_4$
- 3)  $A_1 A_2 A_2' A_3 A_4$
- 4)  $A_1 A_2' A_3 A_4 A_5'$

63. The following diagram represents a finite state machine which takes as input a binary number from the least significant bit.

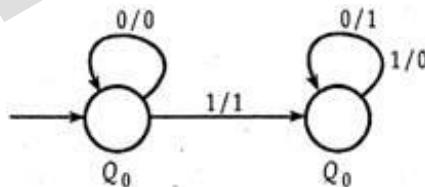

Which one of the following is TRUE?

- 1) It computes 1's complement of the input number
- 2) It computes 2's complement of the input number
- 3) It increments the input number
- 4) It decrements the input number

64. Consider the following circuit

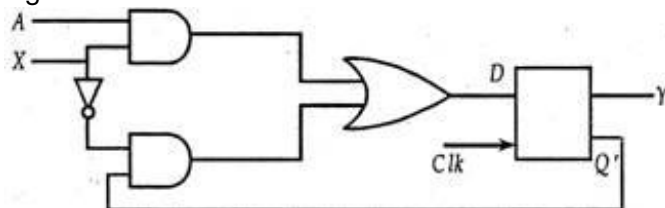

The flip-flops are positive edge triggered D FFs. Each state is designated as a two bit string  $Q_0Q_1$ . Let the initial state be 00. The state transition sequence is:

- 1) 00 → 11 → 01  
↑  
└──────────┘
- 2) 00 → 11  
↑  
└───┘
- 3) 00 → 10 → 01 → 11  
↑  
└──────────┘
- 4) 00 → 11 → 01 → 10  
↑  
└──────────┘

65. Consider a three word machine instruction

ADD A[R0], @ B

The first operand (destination) "A [R0]" uses indexed addressing mode with R0 as the index register. The second operand (source) "@ B" uses indirect addressing mode. A and B are memory addresses residing at the second and the third words, respectively. The first word of the instruction specifies the opcode, the index register designation and the source and destination addressing modes. During execution of ADD instruction, the two operands are added and stored in the destination (first operand).

The number of memory cycles needed during the execution cycle of the instruction is

- 1) 3
  - 2) 4
  - 3) 5
  - 4) 6
66. Match each of the high level language statements given on the left hand side with the most natural addressing mode from those listed on the right hand side.

1	A[1] = B[J];	a	Indirect addressing
2	while [*A++];	b	Indexed, addressing
3	int temp = *x;	c	Autoincrement

- 1) (1, c), (2, b), (3, a)
  - 2) (1, a), (2, c), (3, b)
  - 3) (1, b), (2, c), (3, a)
  - 4) (1, a), (2, b), (3, c)
67. Consider a direct mapped cache of size 32 KB with block size 32 bytes. The CPU generates 32 bit addresses. The number of bits needed for cache indexing and the number of tag bits are respectively
- 1) 10, 17
  - 2) 10, 22
  - 3) 15, 17
  - 4) 5, 17

68. A 5 stage pipelined CPU has the following sequence of stages:

IF — Instruction fetch from instruction memory,

RD — Instruction decode and register read,

EX — Execute: ALU operation for data and address computation,

MA — Data memory access - for write access, the register read at RD stage is used,

WB — Register write back.

Consider the following sequence of instructions:

I<sub>1</sub> : L R0, 10c1;      R0 <= M[10c1]

I<sub>2</sub> : A R0, R0;      R0 <= R0 + R0

I<sub>3</sub> : A R2, R0;      R2 <= R2 - R0

Let each stage take one clock cycle.

What is the number of clock cycles taken to complete the above sequence of instructions starting from the fetch of I<sub>1</sub> ?

- 1) 8                                      2) 10                                      3) 12                                      4) 15

69. A device with data transfer rate 10 KB/sec is connected to a CPU. Data is transferred byte-wise. Let the interrupt overhead be 4 msec. The byte transfer time between the device interface register and CPU or memory is negligible. What is the minimum performance gain of operating the device under interrupt mode over operating it under program controlled mode?

- 1) 15                                      2) 25                                      3) 35                                      4) 45

70. Consider a disk drive with the following specifications:

16 surfaces, 512 tracks/surface, 512 sectors/track, 1 KB/sector, rotation speed 3000 rpm. The disk is operated in cycle stealing mode whereby whenever one byte word is ready it is sent to memory; similarly, for writing, the disk interface reads a 4 byte word from the memory in each DMA cycle. Memory cycle time is 40 nsec. The maximum percentage of time that the CPU gets blocked during DMA operation is

- 1) 10                                      2) 25                                      3) 40                                      4) 50

71. Suppose n processes, P<sub>1</sub>, ..., P<sub>n</sub> share m identical resource units, which can be reserved and released one at a time. The maximum resource requirement of process P<sub>i</sub> is s<sub>p</sub> where s<sub>i</sub> > 0. Which one of the following is a sufficient condition for ensuring that deadlock does not occur?

1)  $\forall i, s_i < m$

2)  $\forall i, s_i < n$

3)  $\sum_{i=1}^n s_i < (m + n)$

4)  $\sum_{i=1}^n s_i (m * n)$

72. Consider the following code fragment:

```
it (fork ( ) == 0)
```

```
{a = a + 5; print f ("%d, %d /m", a, and a); }
```

```
else {a - 5; print f ("%d, %d /n", a, & a); }
```

Let u, n be the values printed by the parent process, and x, y be the values printed by the child process. Which one of the following is TRUE?

1) u = x + 10 and v = y

2) u = x + 10 and v ≠ y

3) u + 10 = x and v = y

4) u + 10 = x and v ≠ y

73. In a packet switching network, packets are routed from, source to destination along a single path having two intermediate nodes. If the message size is 24 bytes and each packet contains a header of 3 bytes, then the optimum packet size is

- 1) 4                                      2) 6                                      3) 7                                      4) 9

74. Suppose the round trip propagation delay for a 10 Mbps Ethernet having 48-bit jamming signal is 46.4 ms. The minimum frame size is

- 1) 94                                      2) 416                                      3) 464                                      4) 512

75. Let  $E_1$  and  $E_2$  be two entities in an E/R diagram with simple single-valued attributes.  $R_1$  and  $R_2$  are two relationships between  $E_1$  and  $E_2$ , where  $R_1$  is one-to-many and  $R_2$  is many-to-many.  $R_1$  and  $R_2$  do not have any attributes of their own. What is the minimum number of tables required to represent this situation in the relational model?

- 1) 2                                      2) 3                                      3) 4                                      4) 5

76. The following table has two attributes A and C where A is the primary key and C is the foreign key referencing A with on-delete cascade.

A	C
2	4
3	4
4	3
5	2
7	2
9	5
6	4

The set of all tuples that must be additionally deleted to preserve referential integrity when the tuple (2, 4) is deleted is:

- 1) (3, 4) and (6, 4)  
 2) (5, 2) and (7, 2)  
 3) (5, 2) (7, 2) and (9, 5)  
 4) (3, 4) (4, 3) and (6, 4)

77. The relation book (title, price) contains the titles and prices of different books. Assuming that no two books have the same price, what does the following SQL

```
select title
from book as B
where (select count (*)
from book as T
where T.price > B.price) < 5
```

- 1) Titles of the four most expensive books  
 2) Title of the fifth most inexpensive book  
 3) Title of the fifth most expensive book  
 4) Titles of the five most expensive books



78. Consider a relation scheme  $R = (A, B, C, D, E, H)$  on which the following functional dependencies hold :  $\{A \rightarrow B, BC \rightarrow D, E \rightarrow C, D \rightarrow A\}$ . What are the candidate keys of  $R$ ?

- 1) AE, BE
- 2) AE, BE, DE
- 3) AEH, BEH, BCH
- 4) AEH, BEH, DEH

Consider the following data path of a CPU

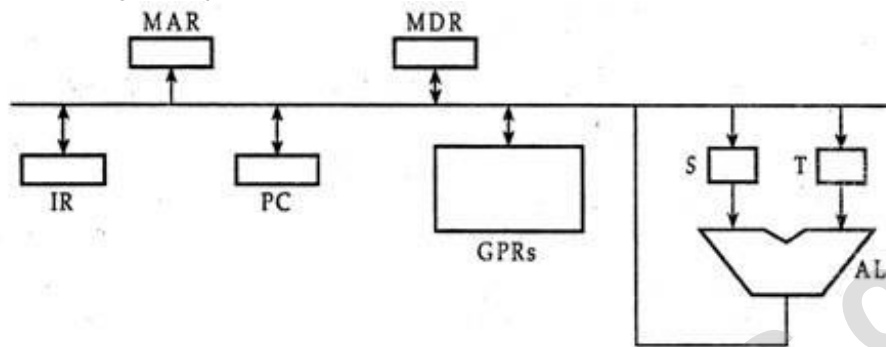

The, ALU, the bus and all the registers in the data path are of identical size. All operations including incrementation of the PC and the GPRs are to be carried out in the ALU. Two clock cycles are needed for memory read operation - the first one for loading address in the MAR and the next one for loading data from the memory bus into the MDR

79. The instruction "add R0, R1" has the register transfer interpretation  $R0 \leftarrow R0 + R1$ . The minimum number of clock cycles needed for execution cycle of this instruction is

- 1) 2
- 2) 3
- 3) 4
- 4) 5

80. The instruction "call Rn, sub" is a two word instruction. Assuming that PC is incremented during the fetch cycle of the first word of the instruction, its register transfer interpretation is

$$Rn \leftarrow PC + 1;$$

$$PC \leftarrow M[PC];$$

The minimum number of CPU clock cycles needed during the execution cycle of this instruction is:

- 1) 2
- 2) 3
- 3) 4
- 4) 5

81a. The space complexity of the above function is

- 1)  $O(1)$
- 2)  $O(n)$
- 3)  $O(n!)$
- 4)  $O(n^n)$

81b. Suppose we modify the above function  $foo()$  and store the values of  $foo(i)$ ,  $0 \leq i < n$ , as and when they are computed. With this modification, the time complexity for function  $foo()$  is significantly reduced. The space complexity of the modified function would be:

- 1)  $O(1)$

- 2)  $O(n)$
- 3)  $O(n^2)$
- 4)  $O(n!)$

82a. The edge  $e$  must definitely belong to:

- 1) the minimum weighted spanning tree of  $G$
- 2) the weighted shortest path from  $s$  to  $t$
- 3) each path from  $s$  to  $t$
- 4) the weighted longest path from  $s$  to  $t$

82b. Let the weight of an edge  $e$  denote the congestion on that edge. The congestion on a path is defined to be the maximum of the congestions on the edges of the path. We wish to find the path from  $s$  to  $t$  having minimum congestion. Which one of the following paths is always such a path of minimum congestion?

- 1) a path from  $s$  to  $t$  in the minimum weighted spanning tree
- 2) a weighted shortest path from  $s$  to  $t$
- 3) an Euler walk from  $s$  to  $t$
- 4) a Hamiltonian path from  $s$  to  $t$

83a. The above grammar and the semantic rules are fed to a yacc tool (which is an LALR (1) parser generator) for parsing and evaluating arithmetic expressions. Which one of the following is true about the action of yacc for the given grammar?

- 1) It detects recursion and eliminates recursion
- 2) It detects reduce-reduce conflict, and resolves
- 3) It detects shift-reduce conflict, and resolves the conflict in favor of a shift over a reduce action
- 4) It detects shift-reduce conflict, and resolves the conflict in favor of a reduce over a shift action

83b. Assume the conflicts in Part (a) of this question are resolved and an LALR (1) parser is generated for parsing arithmetic expressions as per the given grammar. Consider an expression  $3 \times 2 + 1$ . What precedence and associativity properties does the generated parser realize?

- 1) Equal precedence and left associativity; expression is evaluated to 7
- 2) Equal precedence and right associativity; expression is evaluated to 9
- 3) Precedence of ' $\times$ ' is higher than that of '+', and both operators are left associative; expression is evaluated to 7
- 4) Precedence of '+' is higher than that of ' $\times$ ', and both operators are left associative; expression is evaluated to 9

84a. Are all tasks completed in the schedule that gives maximum profit?

- 1) All tasks are completed
- 2)  $T_1$  and  $T_6$  are left out
- 3)  $T_1$  and  $T_8$  are left out

4)  $T_4$  and  $T_6$  are left out

84b. What is the maximum profit earned?

1) 147

2) 165

3) 167

4) 175

85a. The decimal number  $0.239 \times 2^{13}$  has the following hexadecimal representation (without normalization and rounding off :

1) 0D 24

2) 0D 4D

3) 4D 0D

4) 4D 3D

85b. The normalized representation for the above format is specified as follows.

The mantissa has an implicit 1 preceding the binary (radix) point. Assume that only 0's are padded in while shifting a field.

The normalized representation of the above number ( $0.239 \times 2^{13}$ ) is:

1) 0A 20

2) 11 34

3) 4D D0

4) 4A E8

### Answer Key

1) 3	2) 3	3) 3	4) 2	5) 1	6) 3	7) 4	8) 1	9) 2	10) 1
11) 1	12) 3	13) 3	14) 2	15) 1	16) 1	17) 1	18) 1	19) 2	20) 1
21) 2	22) 3	23) 2	24) 4	25) 2	26) 2	27) 4	28) 4	29) 3	30) 3
31) 4	32) 4	33) 1	34) 4	35) 2	36) 3	37) 2	38) 2	39) 1	40) 2
41) 2	42) 3	43) 2	44) 3	45) 1	46) 2	47) 1	48) 2	49) 2	50) 2
51) 4	52) 3	53) 2	54) 4	55) 1	56) 2	57) 2	58) 3	59) 4	60) 2
61) 3	62) 1	63) 2	64) 4	65) 3	66) 3	67) 1	68) 1	69) 2	70) 2
71) 3	72) 2	73) 4	74) 4	75) 2	76) 3	77) 1	78) 4	79) 1	80) 4
81a) 3	81b) 2	82a) 1	82b) 2	83a) 3	83b) 1	84a) 4	84b) 1	85a) 4	85b) 4