

# GATE EC 2009

Q.1 - Q. 20 carry one mark each.

1. The order of the differential equation

$$\frac{d^2y}{dr^2} - \frac{dy}{dt} + y^4 e^{-1} = 0$$

- (A) 1 (B) 2  
(C) 3 (D) 4

2. The Fourier series of a real periodic function has only

- P. Cosine terms if it is even  
Q. sine terms if it is even  
R. cosine terms if it is odd  
S. sine terms if it is odd

Which of the above statements are correct?

- (A) P and S (B) P and R  
(C) Q and S (D) Q and R

3. A function is given by  $f(t) = \sin^2 t + \cos 2t$ . Which of the following is true ?

- (A)  $f$  has frequency components at 0 and 1/2 Hz  
(B)  $f$  has frequency components at 0 and 1/ Hz  
(C)  $f$  has frequency components at 1/2 and 1/ Hz  
(D)  $f$  has frequency components at 0.1/2 and 1/ Hz

4. A fully charged mobile phone with a 12 V battery is good for a 10 minute talk-time. Assume that, during the talk-time, the battery delivers a constant current of 2 A and its voltage drops linearly from 12 V to 10 V as shown in the figure. How much energy does the battery deliver during this talk-time ?

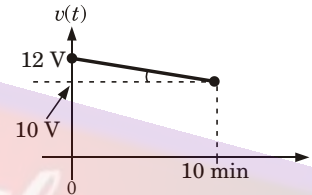

- (A) 220 J (B) 12 kJ  
(C) 13.2 kJ (D) 14.4 kJ

5. In an n-type silicon crystal at room temperature, which of the following can have a concentration of  $4 \times 10^{19} \text{ cm}^{-3}$ ?

- (A) Silicon atoms (B) Holes  
(C) Dopant atoms (D) Valence electrons

6. The full forms of the abbreviations TTL and CMOS in reference to logic families are

- (A) Triple Transistor Logic and Chip Metal Oxide Semiconductor  
(B) Tristate Transistor Logic and Chip Metal Oxide Semiconductor  
(C) Transistor Transistor Logic and Complementary Metal Oxide Semiconductor  
(D) Tristate Transistor Logic and Complementary Metal Oxide Silicon

7. The ROC of Z-transform of the discrete time sequence

$$x(n) = \frac{1}{3} u(n) - \frac{1}{2} u(n-1)$$

- (A)  $\frac{1}{3} < |z| < \frac{1}{2}$  (B)  $|z| < \frac{1}{2}$

- (C)  $|z| = \frac{1}{3}$                       (D)  $2 < |z| < 3$

8. The magnitude plot of a rational transfer function  $G(s)$  with real coefficients is shown below. Which of the following compensators has such a magnitude plot ?

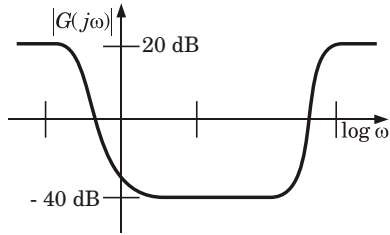

- (A) Lead compensator  
 (B) Lag compensator  
 (C) PID compensator  
 (D) Lead-lag compensator

9. A white noise process  $X(t)$  with two-sided power spectral density  $1 \cdot 10^{10}$  W/Hz is input to a filter whose magnitude squared response is shown below.

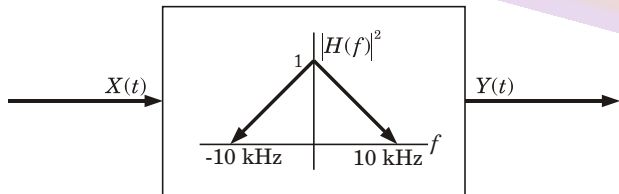

The power of the output process  $Y(t)$  is given by

- (A)  $5 \cdot 10^7$  W                      (B)  $1 \cdot 10^6$  W  
 (C)  $2 \cdot 10^6$  W                      (D)  $1 \cdot 10^5$  W

10. Which of the following statements is true regarding the fundamental mode of the metallic waveguides shown ?

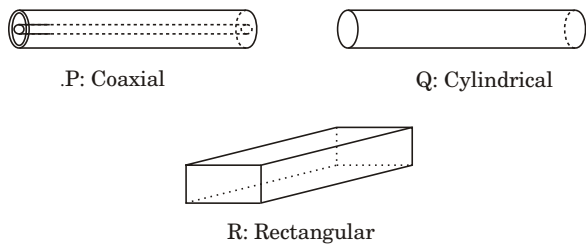

- (A) Only P has no cutoff-frequency  
 (B) Only Q has no cutoff-frequency  
 (C) Only R has no cutoff-frequency  
 (D) All three have cut-off frequencies

11. A fair coin is tossed 10 times. What is the probability that ONLY the first two tosses will yield heads ?

- (A)  $\frac{1}{2}^2$                                       (B)  $^{10}C_2 \frac{1}{2}^2$   
 (C)  $\frac{1}{2}^{10}$                                       (D)  $^{10}C_2 \frac{1}{2}^{10}$

12. If the power spectral density of stationary random process is a sinc-squared function of frequency, the shape of its autocorrelation is

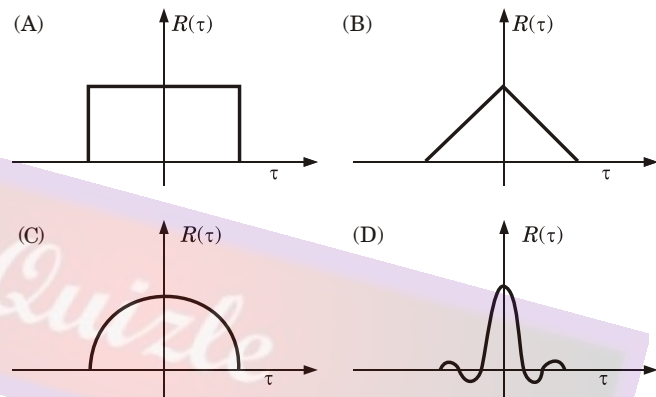

13. If  $f(z) = c_0 + c_1 z^{-1}$ , then  $\oint_{\text{unit circle}} \frac{1+f(z)}{z} dz$  is given by

- (A)  $2 c_1$                                       (B)  $2 (1 - c_0)$   
 (C)  $2 j c_1$                                       (D)  $2 j (1 - c_0)$

14. In the interconnection of ideal sources shown in the figure, it is known that the 60 V source is absorbing power.

Which of the following can be the value of the current source  $I$  ?

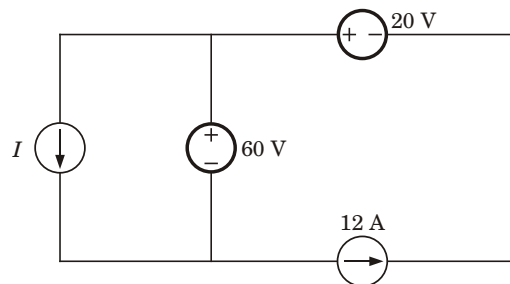

- (A) 10 A                                      (B) 13 A  
 (C) 15 A                                      (D) 18 A

15. The ratio of the mobility to the diffusion coefficient in a semiconductor has the units

- (A)  $V^{-1}$  (B)  $\text{cm} \cdot V^{-1}$   
 (C)  $V \cdot \text{cm}^{-1}$  (D)  $V \cdot s$

16. In a microprocessor, the service routine for a certain interrupt starts from a fixed location of memory which cannot be externally set, but the interrupt can be delayed or rejected. Such an interrupt is

- (A) non-maskable and non-vectorized  
 (B) maskable and non-vectorized  
 (C) non-maskable and vectorized  
 (D) maskable and vectorized

17. If the transfer function of the following network is  $\frac{V_o(s)}{V_i(s)} = \frac{1}{2 + sCR}$  the value of the load resistance  $R_L$  is

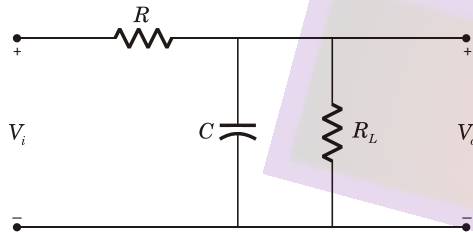

- (A)  $R/4$  (B)  $R/2$   
 (C)  $R$  (D)  $2R$

18. Consider the system  $\frac{dx}{dt} = Ax + Bu$  with  $A = \begin{bmatrix} 1 & 0 \\ 0 & 1 \end{bmatrix}$

and  $B = \begin{bmatrix} p \\ q \end{bmatrix}$  where  $p$  and  $q$  are arbitrary real numbers.

Which of the following statements about the controllability of the system is true?

- (A) The system is completely state controllable for any nonzero values of  $p$  and  $q$   
 (B) Only  $p = 0$  and  $q = 0$  result in controllability  
 (C) The system is uncontrollable for all values of  $p$  and  $q$   
 (D) We cannot conclude about controllability from the given data

19. For a message signal  $m(t) = \cos(2f_m t)$  and carrier of frequency  $f_c$ , which of the following represents a single side-band (SSB) signal?

- (A)  $\cos(2f_m t) \cos(2f_c t)$   
 (B)  $\cos(2f_c t)$   
 (C)  $\cos[2(f_c - f_m)t]$   
 (D)  $[1 + \cos(2f_m t)] \cos(2f_c t)$

20. Two infinitely long wires carrying current are as shown in the figure below. One wire is in the  $y-z$  plane and parallel to the  $y$  axis. The other wire is in the  $x-y$  plane and parallel to the  $x$  axis. Which components of the resulting magnetic field are non-zero at the origin?

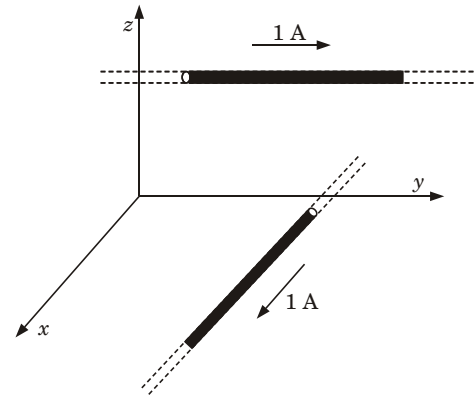

- (A)  $x, y, z$  components (B)  $x, y$  components  
 (C)  $y, z$  components (D)  $x, z$  components

Q. 21 to Q. 60 carry two marks each.

21. Consider two independent random variables  $X$  and  $Y$  with identical distributions. The variables  $X$  and  $Y$  take values 0, 1 and 2 with probabilities  $\frac{1}{2}$ ,  $\frac{1}{4}$  and  $\frac{1}{4}$  respectively. What is the conditional probability  $P(X = 2 | X + Y = 0)$ ?

- (A) 0 (B)  $\frac{1}{16}$   
 (C)  $\frac{1}{6}$  (D) 1

22. The Taylor series expansion of  $\frac{\sin x}{x}$  at  $x = 0$  is given by

- (A)  $1 - \frac{(x)^2}{3!} + \dots$  (B)  $1 + \frac{(x)^2}{3!} + \dots$   
 (C)  $1 - \frac{(x)^2}{3!} + \dots$  (D)  $1 + \frac{(x)^2}{3!} + \dots$

23. If a vector field  $V$  is related to another vector field  $A$  through  $\nabla \cdot V = A$ , which of the following is true? Note:  $C$  and  $S_C$  refer to any closed contour and any surface whose boundary is  $C$ .

- (A)  $\oint_C V \cdot dl = \int_{S_C} A \cdot dS$  (B)  $\oint_C A \cdot dl = \int_{S_C} V \cdot dS$   
 (C)  $\oint_C V \cdot dl = \int_{S_C} A \cdot dS$  (D)  $\oint_C A \cdot dl = \int_{S_C} V \cdot dS$

24. Given that  $F(s)$  is the one-sided Laplace transform of  $f(t)$ , the Laplace transform of  $\int_0^t f(\tau) d\tau$  is

- (A)  $sF(s) - f(0)$  (B)  $\frac{1}{s} F(s)$   
 (C)  $\frac{s}{s^2} F(s) - f(0)$  (D)  $\frac{1}{s} [F(s) - f(0)]$

25. Match each differential equation in Group I to its family of solution curves from Group II.

- |                                  |                   |
|----------------------------------|-------------------|
| Group I                          | Group II          |
| P. $\frac{dy}{dx} = \frac{y}{x}$ | 1. Circles        |
| Q. $\frac{dy}{dx} = \frac{y}{x}$ | 2. Straight lines |
| R. $\frac{dy}{dx} = \frac{x}{y}$ | 3. Hyperbolas     |
| S. $\frac{dy}{dx} = \frac{x}{y}$ |                   |

- (A) P 2, Q 3, R 3, S 1  
 (B) P 1, Q 3, R 2, S 1  
 (C) P 2, Q 1, R 3, S 3  
 (D) P 3, Q 2, R 1, S 2

26. The eigen values of the following matrix are

$$\begin{bmatrix} 1 & 3 & 5 \\ 3 & 1 & 6 \\ 0 & 0 & 3 \end{bmatrix}$$

- (A) 3, 3, 5j, 6 - j (B) 6, 5j, 3 - j, 3 + j  
 (C) 3 - j, 3 + j, 5 - j (D) 3, 1, 3j, 1 - 3j

27. An AC source of RMS voltage 20 V with internal impedance  $Z_s = (1 + 2j)\Omega$  feeds a load of impedance  $Z_L = (7 + 4j)\Omega$  in the figure below. The reactive power consumed by the load is

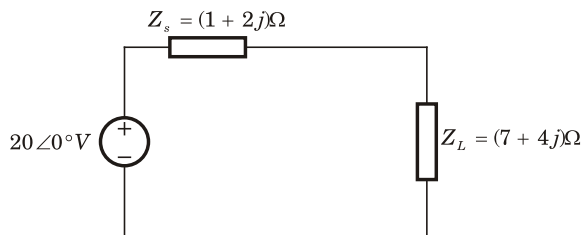

- (A) 8 VAR (B) 16 VAR  
 (C) 28 VAR (D) 32 VAR

28. The switch in the circuit shown was on position  $a$  for a long time, and is moved to position  $b$  at time  $t = 0$ . The current  $i(t)$  for  $t > 0$  is given by

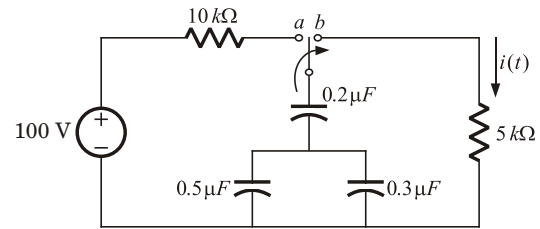

- (A)  $0.2e^{-125t}u(t)$  mA (B)  $20e^{-1250t}u(t)$  mA  
 (C)  $0.2e^{-1250t}u(t)$  mA (D)  $20e^{-1000t}u(t)$  mA

29. In the circuit shown, what value of  $R_L$  maximizes the power delivered to  $R_L$ ?

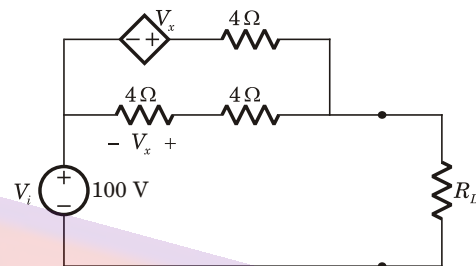

- (A) 2.4 (B)  $\frac{8}{3}$   
 (C) 4 (D) 6

30. The time domain behavior of an  $RL$  circuit is represented by

$$L \frac{di}{dt} + Ri = V_0(1 - e^{-Rt/L} \sin t)u(t).$$

For an initial current of  $i(0) = \frac{V_0}{R}$ , the steady state value of the current is given by

- (A)  $i(t) = \frac{V_0}{R}$  (B)  $i(t) = \frac{2V_0}{R}$   
 (C)  $i(t) = \frac{V_0}{R}(1 - B)$  (D)  $i(t) = \frac{2V_0}{R}(1 - B)$

31. In the circuit below, the diode is ideal. The voltage  $V$  is given by

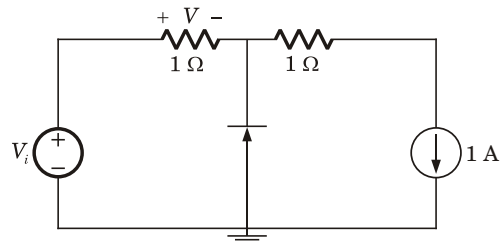

- (A)  $\min(V_i, 1)$  (B)  $\max(V_i, 1)$   
 (C)  $\min(V_i, 1)$  (D)  $\max(V_i, 1)$

**32.** Consider the following two statements about the internal conditions in an n-channel MOSFET operating in the active region.

S1 : The inversion charge decreases from source to drain

S2 : The channel potential increases from source to drain.

Which of the following is correct ?

- (A) Only S2 is true
- (B) Both S1 and S2 are false
- (C) Both S1 and S2 are true, but S2 is not a reason for S1
- (D) Both S1 and S2 are true, and S2 is a reason for S1

**33.** In the following a stable multivibrator circuit, which properties of  $v_o(t)$  depend on  $R_2$  ?

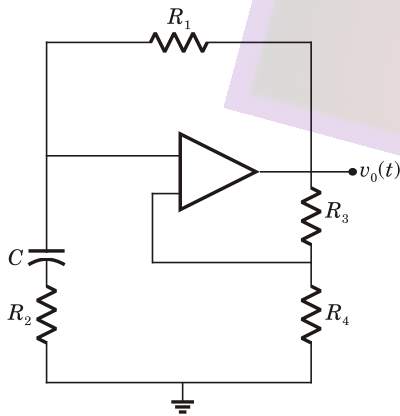

- (A) Only the frequency
- (B) Only the amplitude
- (C) Both the amplitude and the frequency
- (D) Neither the amplitude nor the frequency

**34.** In the circuit shown below, the op-amp is ideal, the transistor has  $V_{BE} = 0.6 \text{ V}$  and  $\beta = 150$ . Decide whether the feedback in the circuit is positive or negative and determine the voltage  $V$  at the output of the op-amp.

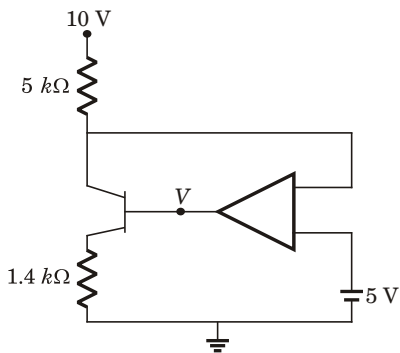

- (A) Positive feedback,  $V = 10 \text{ V}$ .
- (B) Positive feedback,  $V = 0 \text{ V}$
- (C) Negative feedback,  $V = 5 \text{ V}$
- (D) Negative feedback,  $V = 2 \text{ V}$

**35.** A small signal source  $v_i(t) = A \cos 20t + B \sin 10^6 t$  is applied to a transistor amplifier as shown below. The transistor has  $\beta = 150$  and  $h_{ie} = 3 \text{ k}\Omega$ . Which expression best approximates  $v_o(t)$  ?

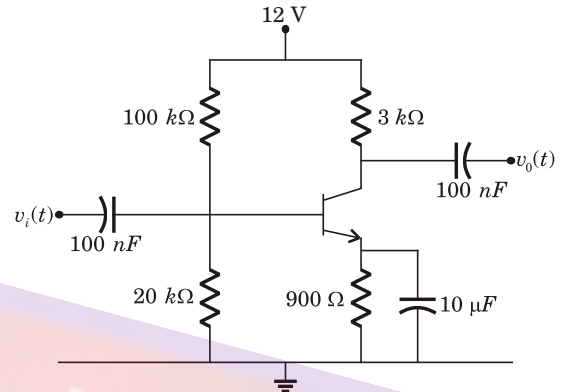

- (A)  $v_o(t) = 1500(A \cos 20t + B \sin 10^6 t)$
- (B)  $v_o(t) = 150(A \cos 20t + B \sin 10^6 t)$
- (C)  $v_o(t) = 1500B \sin 10^6 t$
- (D)  $v_o(t) = 150B \sin 10^6 t$

**36.** If  $X = 1$  in the logic equation

$$[X + Z(\bar{Y} + (\bar{Z} + X\bar{Y}))][\bar{X} + \bar{Z}(X + Y)] = 1, \text{ then}$$

- (A)  $Y = Z$
- (B)  $Y = \bar{Z}$
- (C)  $Z = 1$
- (D)  $Z = 0$

**37.** What are the minimum number of 2-to-1 multiplexers required to generate a 2-input AND gate and a 2-input Wx-OR gate ?

- (A) 1 and 2
- (B) 1 and 3
- (C) 1 and 1
- (D) 2 and 2

**38.** Refer to the NAND and NOR latches shown in the figure. The inputs  $(P_1, P_2)$  for both the latches are first made (0,1) and then, after a few seconds, made (1,1). The corresponding stable outputs  $(Q_1, Q_2)$  are

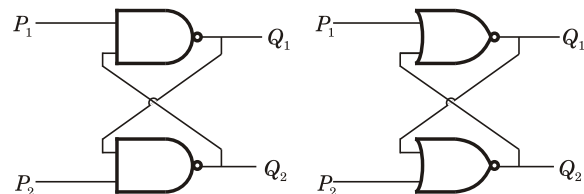

- (A) NAND: first (0,1) then (0,1) NOR: first (1,0) then (0,0)
- (B) NAND: first (1,0) then (1,0) NOR: first (1,0) then (1,0)
- (C) NAND: first (1,0) then (1,0) NOR: first (1,0) then (0,0)
- (D) NAND: first (1,0) then (1,1) NOR: first (0,1) then (0,1)

39. What are the counting states ( $Q_1, Q_2$ ) for the counter shown in the figure below?

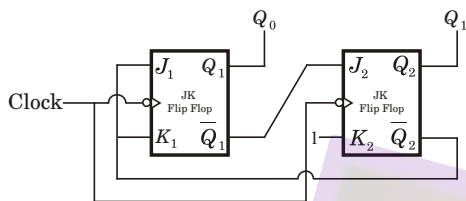

- (A) 11, 10, 00, 11, 10,...
- (B) 01, 10, 11, 00, 01,...
- (C) 00, 11, 01, 10, 00,...
- (D) 01, 10, 00, 01, 10,...

40. A system with transfer function  $H(z)$  has impulse response  $h(\cdot)$  defined as  $h(2) = 1, h(3) = 1$  and  $h(k) = 0$  otherwise. Consider the following statements.

S1:  $H(z)$  is a low-pass filter.

S2:  $H(z)$  is an FIR filter.

Which of the following is correct?

- (A) Only S2 is true
- (B) Both S1 and S2 are false
- (C) Both S1 and S2 are true, and S2 is a reason for S1
- (D) Both S1 and S2 are true, but S2 is not a reason for S1

41. Consider a system whose input  $x$  and output  $y$  are related by the equation

$$y(t) = x(t) + h(2) \cdot d$$

where  $h(t)$  is shown in the graph.

Which of the following four properties are possessed by the system ?

BIBO: Bounded input gives a bounded output.

Causal: The system is causal,

LP: The system is low pass.

LTI: The system is linear and time-invariant.

(

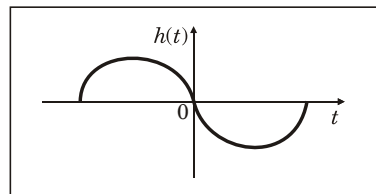

- (A) Causal, LP
- (B) BIBO, LTI
- (C) BIBO, Causal, LTI
- (D) LP, LTI

42. The 4-point Discrete Fourier Transform (DFT) of a discrete time sequence {1,0,2,3} is

- (A)  $[0, -2+2j, 2, -2-2j]$
- (B)  $[2, 2+2j, 6, 2-2j]$
- (C)  $[6, 1-3j, 2, 1+3j]$
- (D)  $[6-1+3j, 0, -1, -3j]$

43. The feedback configuration and the pole-zero locations of  $G(s) = \frac{s^2 - 2s + 2}{s^2 + 2s + 2}$  are shown below. The root locus for negative values of  $k$ , i.e. for  $k < 0$ , has breakaway/break-in points and angle of departure at pole P (with respect to the positive real axis) equal to

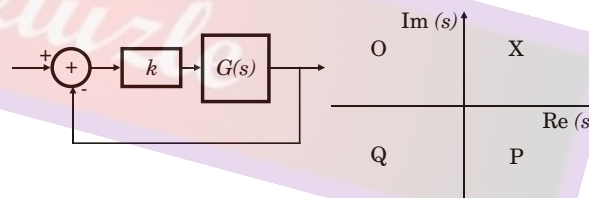

- (A)  $\sqrt{2}$  and 0
- (B)  $\sqrt{2}$  and 45
- (C)  $\sqrt{3}$  and 0
- (D)  $\sqrt{3}$  and 45

44. An LTI system having transfer function  $\frac{s^2 - 1}{s^2 + 2s + 1}$  and input  $x(t) = \sin(t - 1)$  is in steady state. The output is sampled at a rate  $\omega_s$  rad/s to obtain the final output  $\{x(k)\}$ . Which of the following is true?

- (A)  $y(\cdot)$  is zero for all sampling frequencies  $\omega_s$
- (B)  $y(\cdot)$  is nonzero for all sampling frequencies  $\omega_s$
- (C)  $y(\cdot)$  is nonzero for  $\omega_s > 2$ , but zero for  $\omega_s < 2$
- (D)  $y(\cdot)$  is zero for  $\omega_s > 2$ , but nonzero for  $\omega_s < 2$

45. The unit step response of an under-damped second order system has steady state value of -2. Which one of the following transfer functions has these properties ?

- (A)  $\frac{2.24}{s^2 + 2.59s + 1.12}$
- (B)  $\frac{3.82}{s^2 + 1.91s + 1.91}$
- (C)  $\frac{2.24}{s^2 + 2.59s + 1.12}$
- (D)  $\frac{3.82}{s^2 + 1.91s + 1.91}$

46. A discrete random variable  $X$  takes values from 1 to 5 with probabilities as shown in the table. A student calculates the mean of  $X$  as 3.5 and her teacher calculates the variance of  $X$  as 1.5. Which of the following statements is true ?

k	1	2	3	4	5
$P(X = k)$	0.1	0.2	0.4	0.2	0.1

- (A) Both the student and the teacher are right
- (B) Both the student and the teacher are wrong
- (C) The student is wrong but the teacher is right
- (D) The student is right but the teacher is wrong

Q. 47 A message signal given by

$$m(t) = \frac{1}{2} \cos \omega_c t + \frac{1}{2} \sin \omega_c t$$

is amplitude-modulated with a carrier of frequency  $\omega_c$  to generate  $s(t) = [1 + m(t)] \cos \omega_c t$ . What is the power efficiency achieved by this modulation scheme ?

- (A) 8.33%
- (B) 11.11%
- (C) 20%
- (D) 25%

48. A communication channel with AWGN operating at a signal to noise ratio  $SNR \gg 1$  and bandwidth  $B$  has capacity  $C_1$ . If the SNR is doubled keeping  $B$  constant, the resulting capacity  $C_2$  is given by

- (A)  $C_2 = 2C_1$
- (B)  $C_2 = C_1 + B$
- (C)  $C_2 = C_1 + 2B$
- (D)  $C_2 = C_1 + 0.3B$

49. A magnetic field in air is measured to be

$$\mathbf{B} = B_0 \left( \frac{x}{x^2 + y^2} \hat{y} - \frac{y}{x^2 + y^2} \hat{x} \right)$$

What current distribution leads to this field ?

[ Hint : The algebra is trivial in cylindrical coordinates.]

- (A)  $\mathbf{j} = \frac{B_0 \hat{z}}{0} \frac{1}{x^2 + y^2}, \quad r = 0$
- (B)  $\mathbf{j} = \frac{B_0 \hat{z}}{0} \frac{2}{x^2 + y^2}, \quad r = 0$
- (C)  $\mathbf{j} = 0, r = 0$
- (D)  $\mathbf{j} = \frac{B_0 \hat{z}}{0} \frac{1}{x^2 + y^2}, \quad r = 0$

50. A transmission line terminates in two branches, each of length  $\lambda/4$ , as shown. The branches are terminated by  $50 \Omega$  loads. The lines are lossless and have the characteristic impedances shown. Determine the impedance  $Z_i$  as seen by the source.

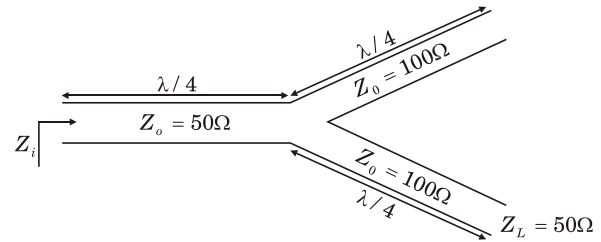

- (A) 200
- (B) 100
- (C) 50
- (D) 25

### Common Date Questions

#### Common Date for Questions 51 and 52:

Consider a silicon p-n junction at room temperature having the following parameters:

- Doping on the n-side  $1 \times 10^{17} \text{ cm}^{-3}$
- Depletion width on the n-side  $0.1 \text{ m}$
- Depletion width on the p-side  $1.0 \text{ m}$
- Intrinsic carrier concentration  $1.4 \times 10^{10} \text{ cm}^{-3}$
- Thermal voltage  $26 \text{ mV}$
- Permittivity of free space  $8.85 \times 10^{-14} \text{ F.cm}^{-1}$
- Dielectric constant of silicon  $12$

51. The built-in potential of the junction

- (A) is 0.70 V
- (B) is 0.76 V
- (C) is 0.82 V
- (D) cannot be estimated from the data given

52. The peak electric field in the device is

- (A)  $0.15 \text{ MV} \cdot \text{cm}^{-1}$ , directed from p-region to n-region
- (B)  $0.15 \text{ MV} \cdot \text{cm}^{-1}$ , directed from n-region to p-region
- (C)  $1.80 \text{ MV} \cdot \text{cm}^{-1}$ , directed from p-region to n-region
- (D)  $1.80 \text{ MV} \cdot \text{cm}^{-1}$ , directed from n-region to p-region

#### Common Date for Questions 53 and 54:

The Nyquist plot of a stable transfer function  $G(s)$  is shown in the figure. We are interested in the stability of the closed loop system in the feedback configuration shown.

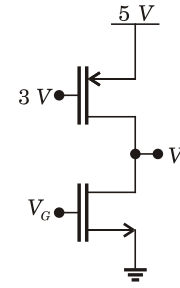
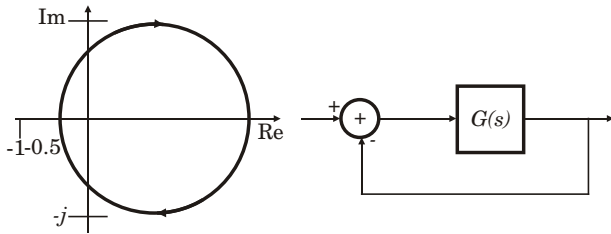

53. Which of the following statements is true?

- (A)  $G(s)$  is an all-pass filter
- (B)  $G(s)$  has a zero in the right-half plane
- (C)  $G(s)$  is the impedance of a passive network
- (D)  $G(s)$  is marginally stable

54. The gain and phase margins of  $G(s)$  for closed loop stability are

- (A) 6 dB and 180
- (B) 3 dB and 180
- (C) 6 dB and 90
- (D) 3 dB and 90

**Common Data for Questions 55 and 56:**

The amplitude of a random signal is uniformly distributed between -5 V and 5 V.

55. If the signal to quantization noise ratio required in uniformly quantizing the signal is 43.5 dB, the step size of the quantization is approximately

- (A) 0.0333 V
- (B) 0.05 V
- (C) 0.0667 V
- (D) 0.10 V

56. If the positive values of the signal are uniformly quantized with a step size of 0.05 V, and the negative values are uniformly quantized with a step size of 0.1 V, the resulting signal to quantization noise ratio is approximately

- (A) 46 dB
- (B) 43.8 dB
- (C) 42 dB
- (D) 40 dB

**Linked Answer Questions**

Statement for Linked Answer Questions 57 and 58:

Consider the CMOS circuit shown, where the gate voltage  $V_G$  of the n-MOSFET is increased from zero, while the gate voltage of the p-MOSFET is kept constant at 3 V. Assume that, for both transistors, the magnitude of the threshold voltage is 1 V and the product of the trans-conductance parameter and the  $\frac{W}{L}$  ratio, i.e. the quantity  $C_{ox} \frac{W}{L}$ , is  $1 \text{ mA} \cdot \text{V}^2$ .

57. For small increase in  $V_G$  beyond 1 V, which of the following gives the correct description of the region of operation of each MOSFET ?

- (A) Both the MOSFETs are in saturation region
- (B) Both the MOSFETs are in triode region
- (C) n-MOSFET is in triode and p-MOSFET is in saturation region
- (D) n-MOSFET is in saturation and p-MOSFET is in triode region.

58. Estimate the output voltage  $V_o$  for  $V_G = 1.5 \text{ V}$ .

[Hint : Use the appropriate current-voltage equation for each MOSFET, based on the answer to Q. 57.]

**Statement for Linked Answer Questions 59 and 60:**

Two products are sold from a vending machine, which has two push buttons  $P_1$  and  $P_2$ . When a button is pressed, the price of the corresponding product is displayed in a 7-segment display.

If no buttons are pressed, **0** is displayed, signifying **Rs. 0**.

If only  $P_1$  is pressed, **2** is displayed, signifying **Rs. 2**.

If only  $P_2$  is pressed, **5** is displayed, signifying **Rs. 5**.

If both  $P_1$  and  $P_2$  are pressed, **E** is displayed, signifying **Error**.

The names of the segments in the 7-segment display, and the glow of the display for '0', '2', '5' and 'E', are shown below.

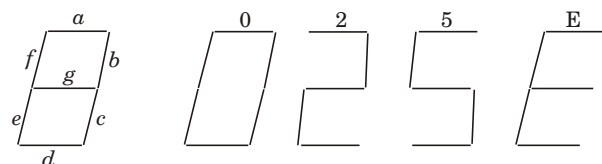



Consider

(i) push button pressed/not pressed is equivalent to logic 1/0 respectively

(ii) a segment glowing/not glowing in the display is equivalent to 1/0 respectively.

**59.** If segments  $a$  to  $g$  are considered as functions of  $P_1$  and  $P_2$ , then which of the following is correct ?

(A)  $g = \bar{P}_1 P_2, d = c = 3$       (B)  $g = P_1 P_2, d = c = e$

(C)  $g = \bar{P}_1 P_2, e = b = c$       (D)  $g = P_1 P_2, e = b = c$

**60.** What are the minimum numbers of NOT gates and 2-input OR gates required to design the logic of the driver for this 7-segment display ?

(A) 3 NOT and 4 OR      (B) 2 NOT and 4 OR

(C) 1 NOT and 3 OR      (D) 2 NOT and 3 OR

## ANSWER

- |       |       |       |       |       |
|-------|-------|-------|-------|-------|
| 1. B  | 2. A  | 3. B  | 4. A  | 5. C  |
| 6. C  | 7. A  | 8. D  | 9. B  | 10. A |
| 11. C | 12. B | 13. D | 14. A | 15. A |
| 16. D | 17. C | 18. C | 19. C | 20. D |
| 21. C | 22. B | 23. B | 24. B | 25. A |
| 26. D | 27. C | 28. C | 29. C | 30. A |
| 31. A | 32. D | 33. A | 34. D | 35. B |
| 36. D | 37. A | 38. C | 39. A | 40. A |
| 41. B | 42. D | 43. B | 44. A | 45. B |
| 46. B | 47. C | 48. B | 49. C | 50. D |
| 51. B | 52.   | 53. B | 54. C | 55. C |
| 56. B | 57. D | 58.   | 59. B | 60. D |

Quizzle