

# Graduate Aptitude Test in Engineering

## Notations :

- Options shown in green color and with ✓ icon are correct.
- Options shown in red color and with ✗ icon are incorrect.

**Question Paper Name:** EC: ELECTRONICS AND COMMUNICATION ENGINEERING 31st Jan Shift2  
**Number of Questions:** 65  
**Total Marks:** 100.0

Wrong answer for MCQ will result in negative marks, (-1/3) for 1 mark Questions and (-2/3) for 2 marks Questions.

## General Aptitude

Number of Questions: 10  
Section Marks: 15.0

Q.1 to Q.5 carry 1 mark each & Q.6 to Q.10 carry 2 marks each.

### Question Number : 1 Question Type : MCQ

Choose the appropriate word/phrase, out of the four options given below, to complete the following sentence:

Dhoni, as well as the other team members of Indian team, \_\_\_\_\_ present on the occasion.

- (A) were                      (B) was                      (C) has                      (D) have

#### Options :

- ✗ A
- ✓ B
- ✗ C
- ✗ D

### Question Number : 2 Question Type : MCQ

Choose the word most similar in meaning to the given word:

Awkward

- (A) Inept                      (B) Graceful                      (C) Suitable                      (D) Dreadful

#### Options :

- ✓ A
- ✗ B
- ✗ C
- ✗ D

### Question Number : 3 Question Type : MCQ

What is the adverb for the given word below?

Misogynous

- (A) Misogynousness    (B) Misogynity    (C) Misogynously    (D) Misogynous

Options :

1. ✘ A
2. ✘ B
3. ✔ C
4. ✘ D

Question Number : 4 Question Type : MCQ

An electric bus has onboard instruments that report the total electricity consumed since the start of the trip as well as the total distance covered. During a single day of operation, the bus travels on stretches M, N, O, and P, in that order. The cumulative distances travelled and the corresponding electricity consumption are shown in the Table below:

Stretch	Cumulative distance (km)	Electricity used (kWh)
M	20	12
N	45	25
O	75	45
P	100	57

The stretch where the electricity consumption per km is minimum is

- (A) M                      (B) N                      (C) O                      (D) P

Options :

1. ✘ A
2. ✘ B
3. ✘ C
4. ✔ D

Question Number : 5 Question Type : MCQ

Ram and Ramesh appeared in an interview for two vacancies in the same department. The probability of Ram's selection is  $\frac{1}{6}$  and that of Ramesh is  $\frac{1}{8}$ . What is the probability that only one of them will be selected?

- (A)  $\frac{47}{48}$   
(B)  $\frac{1}{4}$   
(C)  $\frac{13}{48}$   
(D)  $\frac{35}{48}$

Options :

1. ✘ A
2. ✔ B
3. ✘ C
4. ✘ D

Question Number : 6 Question Type : MCQ

In the following sentence certain parts are underlined and marked P, Q, and R. One of the parts may contain certain error or may not be acceptable in standard written communication. Select the part containing an error. Choose D as your answer if there is no error.

The student corrected all the errors that the instructor marked on the answer book.

- (A) P                      (B) Q                      (C) R                      (D) No Error

Options :

1. ✘ A
2. ✔ B
3. ✘ C
4. ✘ D

Question Number : 7 Question Type : MCQ

Given below are two statements followed by two conclusions. Assuming these statements to be true, decide which one logically follows.

Statements:

- I. All film stars are playback singers.
- II. All film directors are film stars.

Conclusions:

- I. All film directors are playback singers.
- II. Some film stars are film directors.

- (A) Only conclusion I follows.  
(B) Only conclusion II follows.  
(C) Neither conclusion I nor II follows.  
(D) Both conclusions I and II follow.

Options :

1. ✘ A
2. ✘ B
3. ✘ C
4. ✔ D

Question Number : 8 Question Type : NAT

A tiger is 50 leaps of its own behind a deer. The tiger takes 5 leaps per minute to the deer's 4. If the tiger and the deer cover 8 metre and 5metre per leap respectively, what distance in metres will the tiger have to run before it catches the deer?

Correct Answer :

800

Question Number : 9 Question Type : MCQ

If  $a^2 + b^2 + c^2 = 1$ , then  $ab + bc + ac$  lies in the interval

- (A)  $[1, 2/3]$
- (B)  $[-1/2, 1]$
- (C)  $[-1, 1/2]$
- (D)  $[2, -4]$

Options :

- 1. ✘ A
- 2. ✔ B
- 3. ✘ C
- 4. ✘ D

Question Number : 10 Question Type : MCQ

Lamenting the gradual sidelining of the arts in school curricula, a group of prominent artists wrote to the Chief Minister last year, asking him to allocate more funds to support arts education in schools. However, no such increase has been announced in this year's Budget. The artists expressed their deep anguish at their request not being approved, but many of them remain optimistic about funding in the future.

Which of the statement(s) below is/are logically valid and can be inferred from the above statements?

- (i) The artists expected funding for the arts to increase this year.
- (ii) The Chief Minister was receptive to the idea of increasing funding for the arts.
- (iii) The Chief Minister is a prominent artist.
- (iv) Schools are giving less importance to arts education nowadays.

- (A) (iii) and (iv)      (B) (i) and (iv)      (C) (i), (ii) and (iv)      (D) (i) and (iii)

Options :

- 1. ✘ A
- 2. ✔ B
- 3. ✘ C
- 4. ✘ D

Electronics and Communication Engineering

Number of Questions: 55  
Section Marks: 85.0

Q.11 to Q.35 carry 1 mark each & Q.36 to Q.65 carry 2 marks each.

Question Number : 11 Question Type : MCQ

The bilateral Laplace transform of a function  $f(t) = \begin{cases} 1 & \text{if } a \leq t \leq b \\ 0 & \text{otherwise} \end{cases}$

is

- (A)  $\frac{a-b}{s}$       (B)  $\frac{e^s(a-b)}{s}$       (C)  $\frac{e^{-as} - e^{-bs}}{s}$       (D)  $\frac{e^{s(a-b)}}{s}$

Options :

1. ✘ A
2. ✘ B
3. ✔ C
4. ✘ D

Question Number : 12 Question Type : MCQ

The value of  $x$  for which all the eigen-values of the matrix given below are real is

$$\begin{bmatrix} 10 & 5+j & 4 \\ x & 20 & 2 \\ 4 & 2 & -10 \end{bmatrix}$$

- (A)  $5 + j$                       (B)  $5 - j$                       (C)  $1 - 5j$                       (D)  $1 + 5j$

Options :

1. ✘ A
2. ✔ B
3. ✘ C
4. ✘ D

Question Number : 13 Question Type : NAT

Let  $f(z) = \frac{az+b}{cz+d}$ . If  $f(z_1) = f(z_2)$  for all  $z_1 \neq z_2$ ,  $a = 2, b = 4$  and  $c = 5$ , then  $d$  should be equal to \_\_\_\_\_.

Correct Answer :

9.9 to 10.1

Question Number : 14 Question Type : MCQ

The general solution of the differential equation  $\frac{dy}{dx} = \frac{1 + \cos 2y}{1 - \cos 2x}$  is

- (A)  $\tan y - \cot x = c$  ( $c$  is a constant)                      (B)  $\tan x - \cot y = c$  ( $c$  is a constant)  
 (C)  $\tan y + \cot x = c$  ( $c$  is a constant)                      (D)  $\tan x + \cot y = c$  ( $c$  is a constant)

Options :

1. ✘ A
2. ✘ B
3. ✔ C
4. ✘ D

Question Number : 15 Question Type : MCQ

The magnitude and phase of the complex Fourier series coefficients  $a_k$  of a periodic signal  $x(t)$  are shown in the figure. Choose the correct statement from the four choices given. Notation:  $C$  is the set of complex numbers,  $R$  is the set of purely real numbers, and  $P$  is the set of purely imaginary numbers.

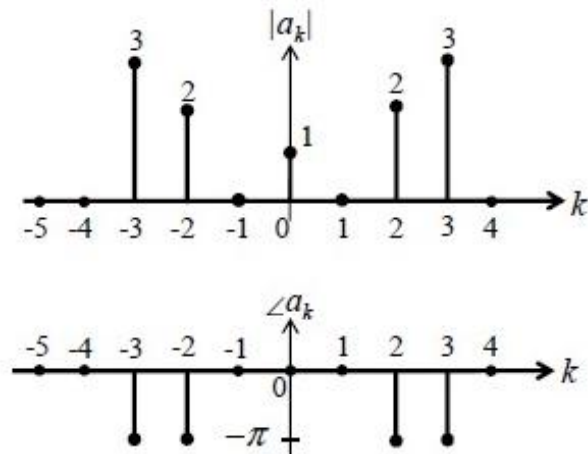

- (A)  $x(t) \in R$   
 (B)  $x(t) \in P$   
 (C)  $x(t) \in (C - R)$   
 (D) the information given is not sufficient to draw any conclusion about  $x(t)$

Options :

1. ✓ A  
 2. ✗ B  
 3. ✗ C  
 4. ✗ D

Question Number : 16 Question Type : NAT

The voltage ( $V_C$ ) across the capacitor (in Volts) in the network shown is \_\_\_\_\_.

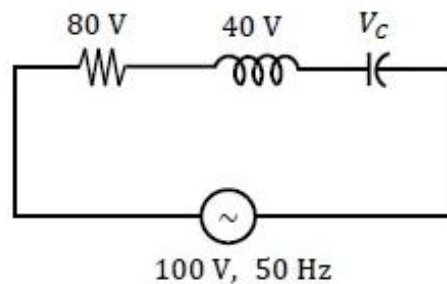

Correct Answer:

100

Question Number : 17 Question Type : NAT

In the circuit shown, the *average* value of the voltage  $V_{ab}$  (in Volts) in steady state condition is \_\_\_\_\_.

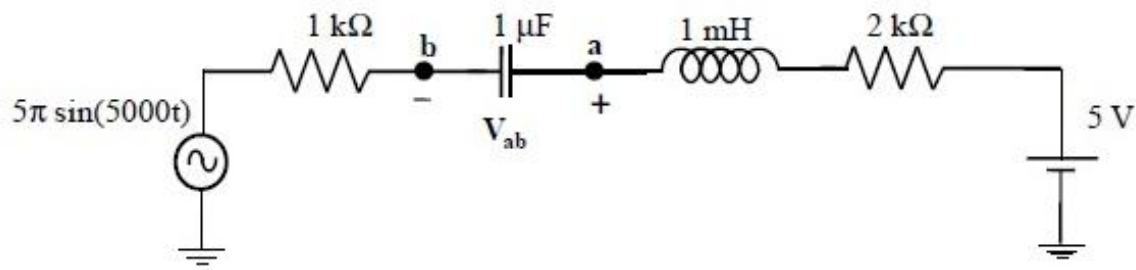

**Correct Answer:**

4.9 to 5.1

**Question Number : 18 Question Type : MCQ**

The 2-port admittance matrix of the circuit shown is given by

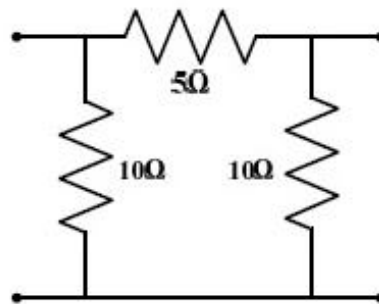

(A)  $\begin{bmatrix} 0.3 & 0.2 \\ 0.2 & 0.3 \end{bmatrix}$

(B)  $\begin{bmatrix} 15 & 5 \\ 5 & 15 \end{bmatrix}$

(C)  $\begin{bmatrix} 3.33 & 5 \\ 5 & 3.33 \end{bmatrix}$

(D)  $\begin{bmatrix} 0.3 & 0.4 \\ 0.4 & 0.3 \end{bmatrix}$

**Options :**

1. ✓ A
2. ✗ B
3. ✗ C
4. ✗ D

**Question Number : 19 Question Type : NAT**

An n-type silicon sample is uniformly illuminated with light which generates  $10^{20}$  electron-hole pairs per  $\text{cm}^3$  per second. The minority carrier lifetime in the sample is  $1 \mu\text{s}$ . In the steady state, the hole concentration in the sample is approximately  $10^x$ , where  $x$  is an integer. The value of  $x$  is \_\_\_\_.

**Correct Answer :**

14

Question Number : 20 Question Type : NAT

A piece of silicon is doped uniformly with phosphorous with a doping concentration of  $10^{16}/\text{cm}^3$ . The expected value of mobility versus doping concentration for silicon assuming full dopant ionization is shown below. The charge of an electron is  $1.6 \times 10^{-19}$  C. The conductivity (in  $\text{S cm}^{-1}$ ) of the silicon sample at 300 K is \_\_\_\_\_.

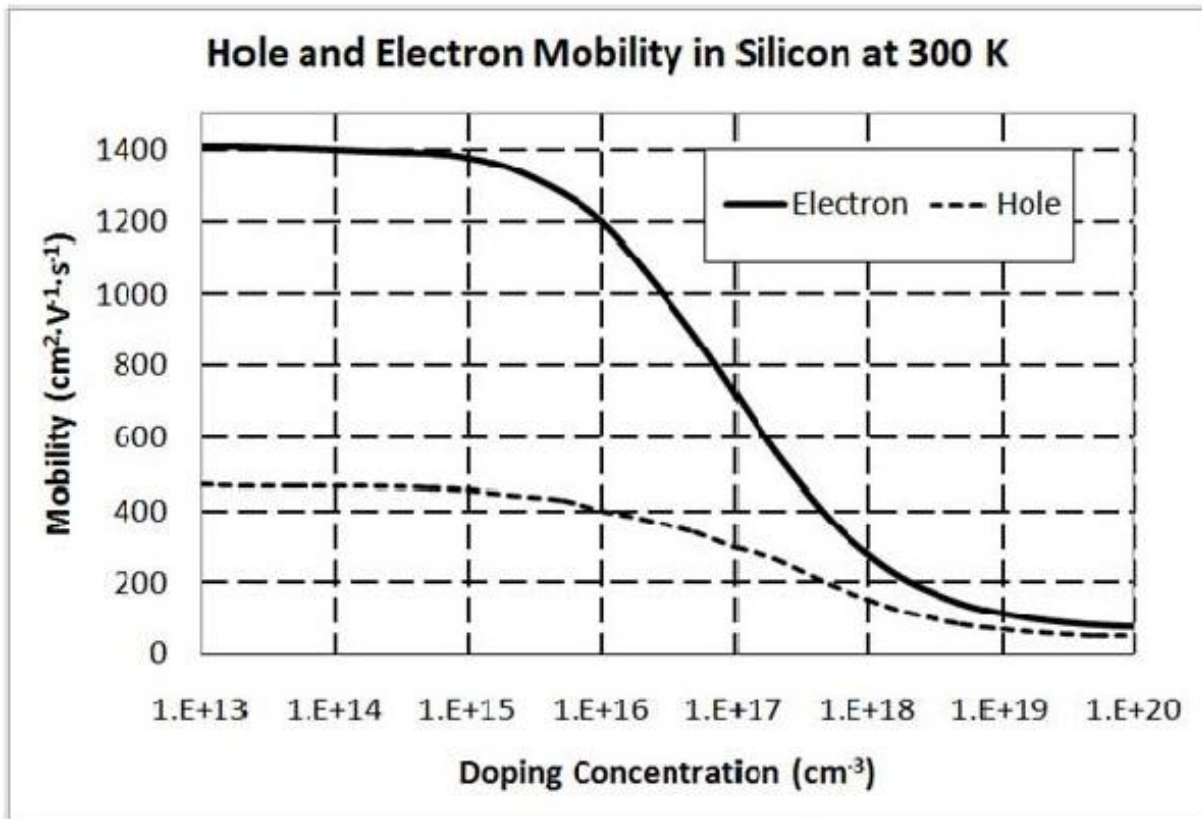

Correct Answer :

1.8 to 2.0

Question Number : 21 Question Type : MCQ

If the circuit shown has to function as a clamping circuit, then which one of the following conditions should be satisfied for the sinusoidal signal of period T ?

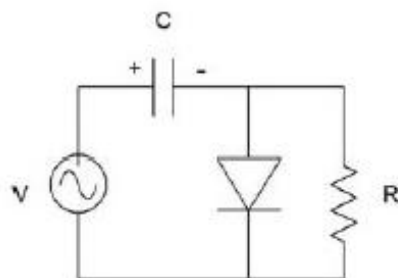

(A)  $RC \ll T$

(B)  $RC = 0.35 T$

(C)  $RC \approx T$

(D)  $RC \gg T$

Options :

1. ✘ A

2. ✘ B



3. ✘ C

4. ✔ D

Question Number : 22 Question Type : NAT

In the circuit shown,  $V_0 = V_{0A}$  for switch SW in position A and  $V_0 = V_{0B}$  for SW in position B.

Assume that the opamp is ideal. The value of  $\frac{V_{0B}}{V_{0A}}$  is \_\_\_\_\_.

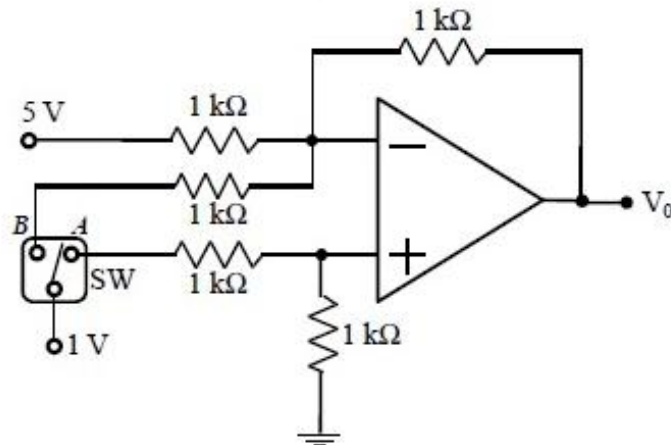

Correct Answer :

1.5

Question Number : 23 Question Type : NAT

In the bistable circuit shown, the ideal opamp has saturation levels of  $\pm 5$  V. The value of  $R_1$  (in  $k\Omega$ ) that gives a hysteresis width of 500 mV is \_\_\_\_\_.

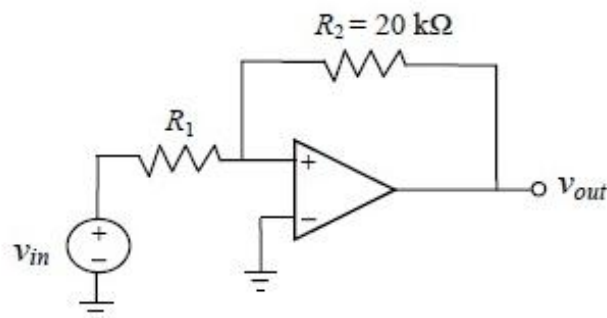

Correct Answer:

1

Question Number : 24 Question Type : MCQ

In the figure shown, the output  $Y$  is required to be  $Y = A B + \bar{C} \bar{D}$ . The gates G1 and G2 must be, respectively,

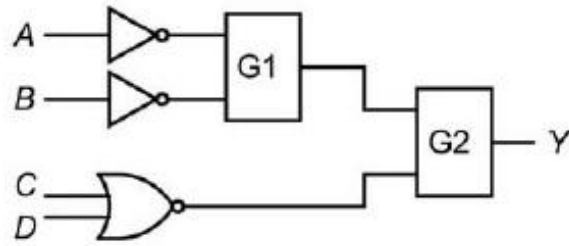

- (A) NOR, OR  
(C) NAND, OR

- (B) OR, NAND  
(D) AND, NAND

Options :

1. ✓ A
2. ✗ B
3. ✗ C
4. ✗ D

Question Number : 25 Question Type : MCQ

In an 8085 microprocessor, which one of the following instructions changes the content of the accumulator?

- (A) MOV B,M      (B) PCHL      (C) RNZ      (D) SBI BEH

Options :

1. ✗ A
2. ✗ B
3. ✗ C
4. ✓ D

Question Number : 26 Question Type : NAT

A mod- $n$  counter using a synchronous binary up-counter with synchronous clear input is shown in the figure. The value of  $n$  is \_\_\_\_\_.

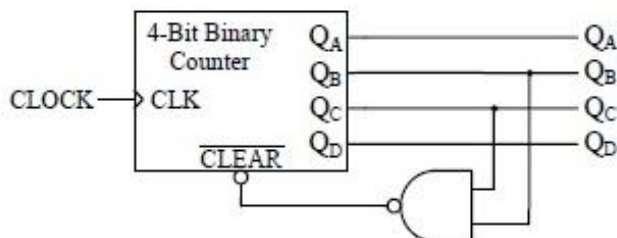

Correct Answer :

7

Question Number : 27 Question Type : MCQ

Let the signal  $f(t) = 0$  outside the interval  $[T_1, T_2]$ , where  $T_1$  and  $T_2$  are finite. Furthermore,  $|f(t)| < \infty$ . The region of convergence (RoC) of the signal's bilateral Laplace transform  $F(s)$  is

- (A) a parallel strip containing the  $j\Omega$  axis
- (B) a parallel strip not containing the  $j\Omega$  axis
- (C) the entire  $s$ -plane
- (D) a half plane containing the  $j\Omega$  axis

Options :

- 1. ✘ A
- 2. ✘ B
- 3. ✔ C
- 4. ✘ D

Question Number : 28 Question Type : NAT

Two causal discrete-time signals  $x[n]$  and  $y[n]$  are related as  $y[n] = \sum_{m=0}^n x[m]$ .

If the  $z$ -transform of  $y[n]$  is  $\frac{2}{z(z-1)^2}$ , the value of  $x[2]$  is \_\_\_\_\_.

Correct Answer :

0

Question Number : 29 Question Type : MCQ

By performing cascading and/or summing/differencing operations using transfer function blocks  $G_1(s)$  and  $G_2(s)$ , one CANNOT realize a transfer function of the form

(A)  $G_1(s)G_2(s)$

(B)  $\frac{G_1(s)}{G_2(s)}$

(C)  $G_1(s) \left( \frac{1}{G_1(s)} + G_2(s) \right)$

(D)  $G_1(s) \left( \frac{1}{G_1(s)} - G_2(s) \right)$

Options :

- 1. ✘ A
- 2. ✔ B
- 3. ✘ C
- 4. ✘ D

Question Number : 30 Question Type : MCQ

For the signal flow graph shown in the figure, the value of  $\frac{C(s)}{R(s)}$  is

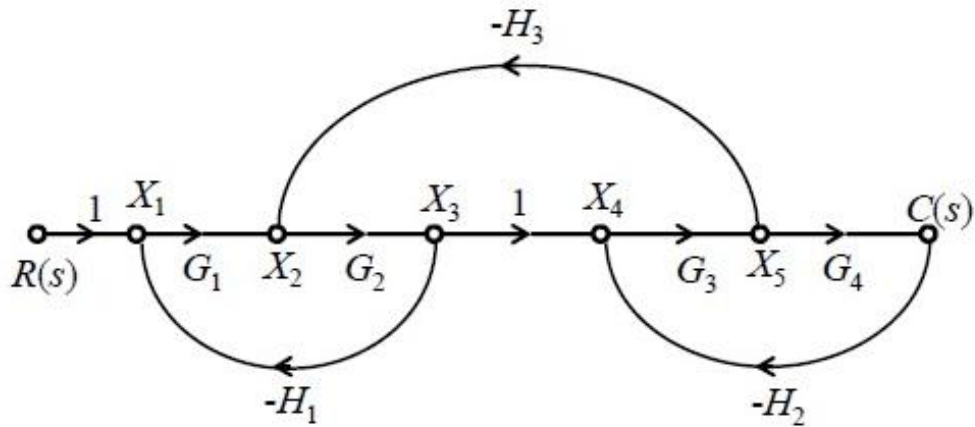

(A) 
$$\frac{G_1 G_2 G_3 G_4}{1 - G_1 G_2 H_1 - G_3 G_4 H_2 - G_2 G_3 H_3 + G_1 G_2 G_3 G_4 H_1 H_2}$$

(B) 
$$\frac{G_1 G_2 G_3 G_4}{1 + G_1 G_2 H_1 + G_3 G_4 H_2 + G_2 G_3 H_3 + G_1 G_2 G_3 G_4 H_1 H_2}$$

(C) 
$$\frac{1}{1 + G_1 G_2 H_1 + G_3 G_4 H_2 + G_2 G_3 H_3 + G_1 G_2 G_3 G_4 H_1 H_2}$$

(D) 
$$\frac{1}{1 - G_1 G_2 H_1 - G_3 G_4 H_2 - G_2 G_3 H_3 + G_1 G_2 G_3 G_4 H_1 H_2}$$

Options :

1. ✘ A
2. ✔ B
3. ✘ C
4. ✘ D

Question Number : 31 Question Type : NAT

A unity negative feedback system has an open-loop transfer function  $G(s) = \frac{K}{s(s+10)}$ . The gain  $K$  for the system to have a damping ratio of 0.25 is \_\_\_\_\_.

Correct Answer :

400

Question Number : 32 Question Type : NAT

A sinusoidal signal of amplitude  $A$  is quantized by a uniform quantizer. Assume that the signal utilizes all the representation levels of the quantizer. If the signal to quantization noise ratio is 31.8 dB, the number of levels in the quantizer is \_\_\_\_\_.

Correct Answer:

32

Question Number : 33 Question Type : MCQ

The signal  $\cos\left(10\pi t + \frac{\pi}{4}\right)$  is ideally sampled at a sampling frequency of 15 Hz. The sampled signal is passed through a filter with impulse response  $\left(\frac{\sin(\pi t)}{\pi t}\right)\cos\left(40\pi t - \frac{\pi}{2}\right)$ . The filter output is

(A)  $\frac{15}{2}\cos\left(40\pi t - \frac{\pi}{4}\right)$

(B)  $\frac{15}{2}\left(\frac{\sin(\pi t)}{\pi t}\right)\cos\left(10\pi t + \frac{\pi}{4}\right)$

(C)  $\frac{15}{2}\cos\left(10\pi t - \frac{\pi}{4}\right)$

(D)  $\frac{15}{2}\left(\frac{\sin(\pi t)}{\pi t}\right)\cos\left(40\pi t - \frac{\pi}{2}\right)$

Options :

1. ✓ A
2. ✗ B
3. ✗ C
4. ✗ D

Question Number : 34 Question Type : NAT

In a source free region in vacuum, if the electrostatic potential  $\varphi = 2x^2 + y^2 + cz^2$ , the value of constant  $c$  must be \_\_\_\_\_.

Correct Answer :

-3.1 to -2.9

Question Number : 35 Question Type : MCQ

The electric field of a uniform plane electromagnetic wave is

$$\vec{E} = (\vec{a}_x + j4\vec{a}_y) \exp[j(2\pi \times 10^7 t - 0.2z)].$$

The polarization of the wave is

- (A) right handed circular (B) right handed elliptical  
(C) left handed circular (D) left handed elliptical

Options :

1. ✘ A  
2. ✘ B  
3. ✘ C  
4. ✔ D

Question Number : 36 Question Type : MCQ

Consider the differential equation  $\frac{dx}{dt} = 10 - 0.2x$  with initial condition  $x(0) = 1$ . The response  $x(t)$  for  $t > 0$  is

- (A)  $2 - e^{-0.2t}$  (B)  $2 - e^{0.2t}$  (C)  $50 - 49e^{-0.2t}$  (D)  $50 - 49e^{0.2t}$

Options :

1. ✘ A  
2. ✘ B  
3. ✔ C  
4. ✘ D

Question Number : 37 Question Type : NAT

The value of the integral  $\int_{-\infty}^{\infty} 12 \cos(2\pi t) \frac{\sin(4\pi t)}{4\pi t} dt$  is \_\_\_\_\_.

Correct Answer :

3

Question Number : 38 Question Type : NAT

If  $C$  denotes the counterclockwise unit circle, the value of the contour integral

$$\frac{1}{2\pi j} \oint_C \operatorname{Re}\{z\} dz$$

is \_\_\_\_\_.

Correct Answer:

0.5

Question Number : 39 Question Type : NAT

Let the random variable  $X$  represent the number of times a fair coin needs to be tossed till two consecutive heads appear for the first time. The expectation of  $X$  is \_\_\_\_\_.

Correct Answer :

1.5

Question Number : 40 Question Type : MCQ

An  $LC$  tank circuit consists of an ideal capacitor  $C$  connected in parallel with a coil of inductance  $L$  having an internal resistance  $R$ . The resonant frequency of the tank circuit is

(A)  $\frac{1}{2\pi\sqrt{LC}}$

(B)  $\frac{1}{2\pi\sqrt{LC}}\sqrt{1-R^2\frac{C}{L}}$

(C)  $\frac{1}{2\pi\sqrt{LC}}\sqrt{1-\frac{L}{R^2C}}$

(D)  $\frac{1}{2\pi\sqrt{LC}}\left(1-R^2\frac{C}{L}\right)$

Options :

1. ✘ A

2. ✔ B

3. ✘ C

4. ✘ D

Question Number : 41 Question Type : NAT

In the circuit shown, the Norton equivalent resistance (in  $\Omega$ ) across terminals a-b is \_\_\_\_\_.

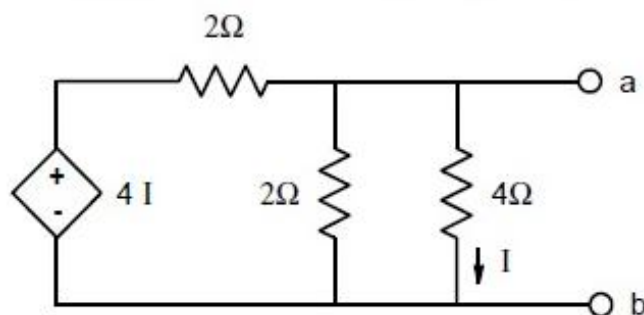

Correct Answer :

1.30 to 1.35

Question Number : 42 Question Type : NAT

In the circuit shown, the initial voltages across the capacitors  $C_1$  and  $C_2$  are 1 V and 3 V, respectively. The switch is closed at time  $t = 0$ . The total energy dissipated (in Joules) in the resistor  $R$  until steady state is reached, is \_\_\_\_\_.

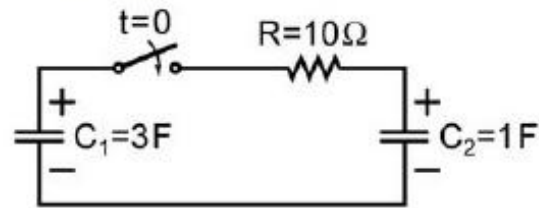

Correct Answer:

1.4 to 1.6

Question Number : 43 Question Type : NAT

A dc voltage of 10 V is applied across an n-type silicon bar having a rectangular cross-section and a length of 1 cm as shown in figure. The donor doping concentration  $N_D$  and the mobility of electrons  $\mu_n$  are  $10^{16} \text{ cm}^{-3}$  and  $1000 \text{ cm}^2\text{V}^{-1}\text{s}^{-1}$ , respectively. The average time (in  $\mu\text{s}$ ) taken by the electrons to move from one end of the bar to other end is \_\_\_\_\_.

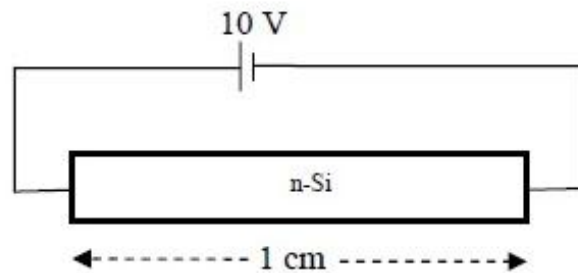

Correct Answer:

95 to 105

Question Number : 44 Question Type : NAT

In a MOS capacitor with an oxide layer thickness of 10 nm, the maximum depletion layer thickness is 100 nm. The permittivities of the semiconductor and the oxide layer are  $\epsilon_s$  and  $\epsilon_{\text{ox}}$  respectively. Assuming  $\epsilon_s/\epsilon_{\text{ox}} = 3$ , the ratio of the maximum capacitance to the minimum capacitance of this MOS capacitor is \_\_\_\_\_.

Correct Answer :

4.3 to 4.4

Question Number : 45 Question Type : MCQ



The energy band diagram and the electron density profile  $n(x)$  in a semiconductor are shown in the figures. Assume that  $n(x) = 10^{15} e^{\left(\frac{q\alpha x}{kT}\right)} \text{ cm}^{-3}$ , with  $\alpha = 0.1 \text{ V/cm}$  and  $x$  expressed in cm. Given  $\frac{kT}{q} = 0.026 \text{ V}$ ,  $D_n = 36 \text{ cm}^2 \text{ s}^{-1}$ , and  $\frac{D}{\mu} = \frac{kT}{q}$ . The electron current density (in  $\text{A/cm}^2$ ) at  $x = 0$  is

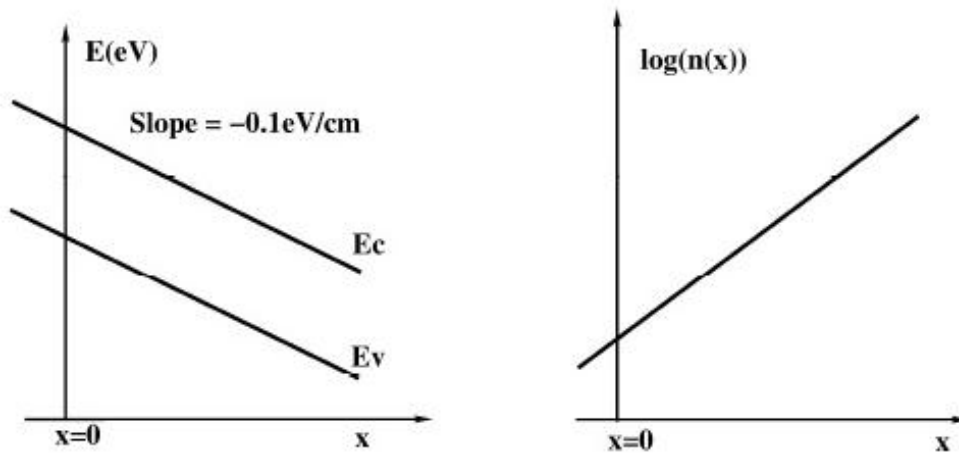

- (A)  $-4.4 \times 10^{-2}$       (B)  $-2.2 \times 10^{-2}$       (C) 0      (D)  $2.2 \times 10^{-2}$

Options :

1. ✘ A
2. ✘ B
3. ✔ C
4. ✘ D

Question Number : 46 Question Type : MCQ

A function of Boolean variables  $X$ ,  $Y$  and  $Z$  is expressed in terms of the min-terms as

$$F(X, Y, Z) = \Sigma (1, 2, 5, 6, 7)$$

Which one of the product of sums given below is equal to the function  $F(X, Y, Z)$ ?

- (A)  $(\bar{X} + \bar{Y} + \bar{Z}) \cdot (\bar{X} + Y + Z) \cdot (X + \bar{Y} + \bar{Z})$
- (B)  $(X + Y + Z) \cdot (X + \bar{Y} + \bar{Z}) \cdot (\bar{X} + Y + Z)$
- (C)  $(\bar{X} + \bar{Y} + Z) \cdot (\bar{X} + Y + \bar{Z}) \cdot (X + \bar{Y} + Z) \cdot (X + Y + \bar{Z}) \cdot (X + Y + Z)$
- (D)  $(X + Y + \bar{Z}) \cdot (\bar{X} + Y + Z) \cdot (\bar{X} + Y + \bar{Z}) \cdot (\bar{X} + \bar{Y} + Z) \cdot (\bar{X} + \bar{Y} + \bar{Z})$

Options :

1. ✘ A
2. ✔ B
3. ✘ C
4. ✘ D

Question Number : 47 Question Type : MCQ

The figure shows a binary counter with synchronous clear input. With the decoding logic shown, the counter works as a

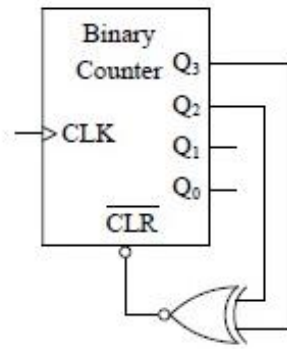

- (A) mod-2 counter      (B) mod-4 counter      (C) mod-5 counter      (D) mod-6 counter

Options :

1. ✘ A
2. ✘ B
3. ✔ C
4. ✘ D

Question Number : 48 Question Type : MCQ

A 1-to-8 demultiplexer with data input  $D_{in}$ , address inputs  $S_0, S_1, S_2$  (with  $S_0$  as the LSB) and  $\bar{Y}_0$  to  $\bar{Y}_7$  as the eight demultiplexed outputs, is to be designed using two 2-to-4 decoders (with enable input  $\bar{E}$  and address inputs  $A_0$  and  $A_1$ ) as shown in the figure.  $D_{in}, S_0, S_1$  and  $S_2$  are to be connected to P, Q, R and S, but not necessarily in this order. The respective input connections to P, Q, R, and S terminals should be

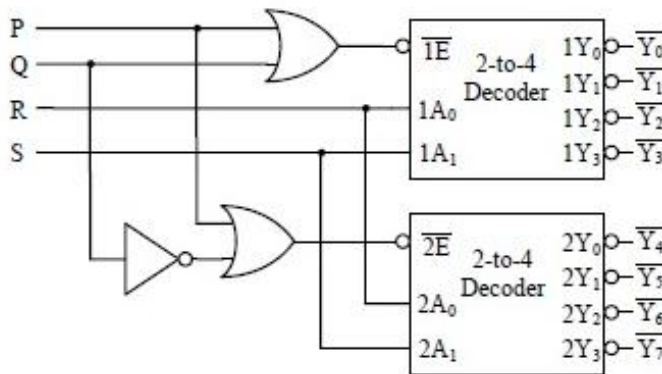

- (A)  $S_2, D_{in}, S_0, S_1$       (B)  $S_1, D_{in}, S_0, S_2$   
 (C)  $D_{in}, S_0, S_1, S_2$       (D)  $D_{in}, S_2, S_0, S_1$

Options :

1. ✘ A
2. ✘ B
3. ✘ C
4. ✔ D

Question Number : 49 Question Type : NAT

The diode in the circuit given below has  $V_{ON} = 0.7\text{ V}$  but is ideal otherwise. The current (in mA) in the  $4\text{ k}\Omega$  resistor is \_\_\_\_\_.

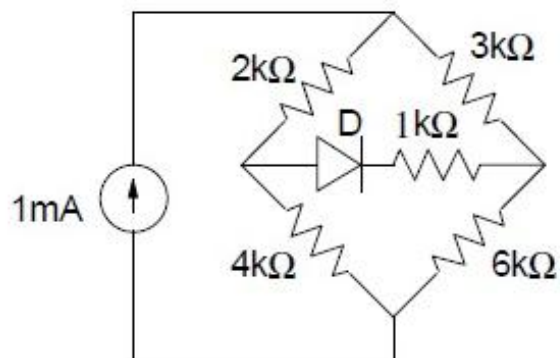

Correct Answer :

0.59 to 0.61

Question Number : 50 Question Type : NAT

Assuming that the opamp in the circuit shown below is ideal, the output voltage  $V_o$  (in volts) is \_\_\_\_\_.

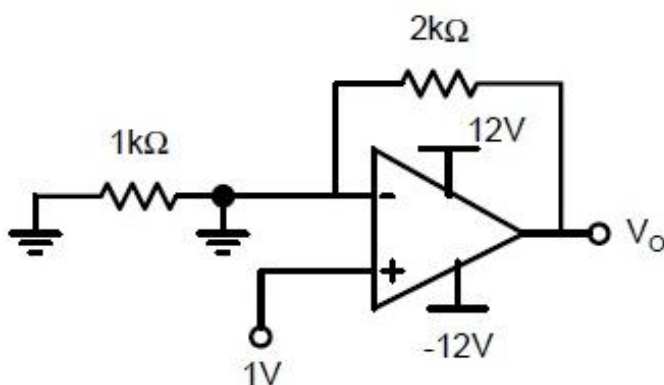

Correct Answer :

11 to 12

Question Number : 51 Question Type : NAT

For the voltage regulator circuit shown, the input voltage ( $V_{in}$ ) is  $20\text{ V} \pm 20\%$  and the regulated output voltage ( $V_{out}$ ) is  $10\text{ V}$ . Assume the opamp to be ideal. For a load  $R_L$  drawing  $200\text{ mA}$ , the maximum power dissipation in  $Q_1$  (in Watts) is \_\_\_\_\_.

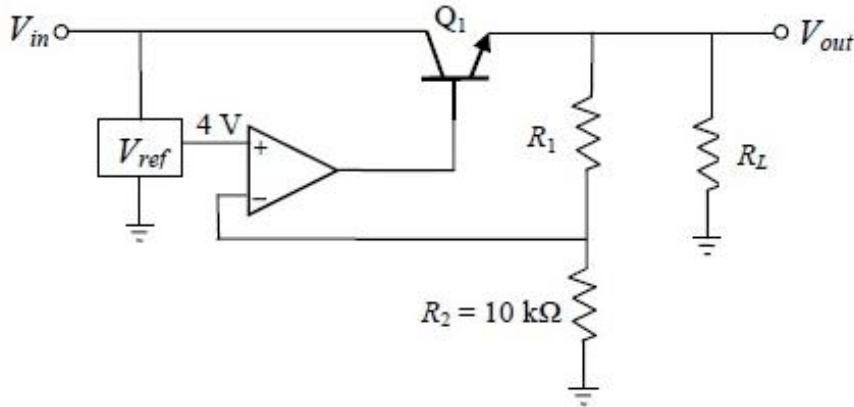

Correct Answer :

2.7 to 2.9

Question Number : 52 Question Type : NAT

In the ac equivalent circuit shown, the two BJTs are biased in active region and have identical parameters with  $\beta \gg 1$ . The open circuit small signal voltage gain is approximately \_\_\_\_\_.

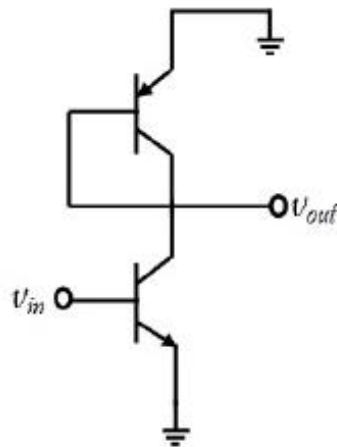

Correct Answer :

-1.1 to -0.9

Question Number : 53 Question Type : MCQ

Input  $x(t)$  and output  $y(t)$  of an LTI system are related by the differential equation  $y''(t) - y'(t) - 6y(t) = x(t)$ . If the system is neither causal nor stable, the impulse response  $h(t)$  of the system is

(A)  $\frac{1}{5}e^{3t}u(-t) + \frac{1}{5}e^{-2t}u(-t)$

(B)  $-\frac{1}{5}e^{3t}u(-t) + \frac{1}{5}e^{-2t}u(-t)$

(C)  $\frac{1}{5}e^{3t}u(-t) - \frac{1}{5}e^{-2t}u(t)$

(D)  $-\frac{1}{5}e^{3t}u(-t) - \frac{1}{5}e^{-2t}u(t)$

Options :

1. ✘ A
2. ✔ B
3. ✘ C
4. ✘ D

Question Number : 54 Question Type : NAT

Consider two real sequences with time-origin marked by the bold value,

$$x_1[n] = \{\mathbf{1}, 2, 3, 0\}, \quad x_2[n] = \{\mathbf{1}, 3, 2, 1\}$$

Let  $X_1(k)$  and  $X_2(k)$  be 4-point DFTs of  $x_1[n]$  and  $x_2[n]$ , respectively.

Another sequence  $x_3[n]$  is derived by taking 4-point inverse DFT of  $X_3(k) = X_1(k)X_2(k)$ .

The value of  $x_3[2]$  is \_\_\_\_\_.

Correct Answer :

10.9 to 11.1

Question Number : 55 Question Type : NAT

Let  $x(t) = \alpha s(t) + s(-t)$  with  $s(t) = \beta e^{-4t}u(t)$ , where  $u(t)$  is unit step function. If the bilateral Laplace transform of  $x(t)$  is

$$X(s) = \frac{16}{s^2 - 16} \quad -4 < \text{Re}\{s\} < 4;$$

then the value of  $\beta$  is \_\_\_\_\_.

Correct Answer :

-2

Question Number : 56 Question Type : MCQ

The state variable representation of a system is given as

$$\dot{x} = \begin{bmatrix} 0 & 1 \\ 0 & -1 \end{bmatrix} x; \quad x(0) = \begin{bmatrix} 1 \\ 0 \end{bmatrix}$$

$$y = [0 \quad 1]x$$

The response  $y(t)$  is

- (A)  $\sin(t)$                       (B)  $1 - e^t$                       (C)  $1 - \cos(t)$                       (D) 0

Options :

1. ✘ A
2. ✘ B
3. ✘ C
4. ✔ D

Question Number : 57 Question Type : MCQ

The output of a standard second-order system for a unit step input is given as

$$y(t) = 1 - \frac{2}{\sqrt{3}} e^{-t} \cos\left(\sqrt{3}t - \frac{\pi}{6}\right). \text{ The transfer function of the system is}$$

- (A)  $\frac{2}{(s+2)(s+\sqrt{3})}$       (B)  $\frac{1}{s^2+2s+1}$                       (C)  $\frac{3}{s^2+2s+3}$                       (D)  $\frac{4}{s^2+2s+4}$

Options :

1. ✘ A
2. ✘ B
3. ✘ C
4. ✔ D

Question Number : 58 Question Type : NAT

The transfer function of a mass-spring-damper system is given by

$$G(s) = \frac{1}{Ms^2 + Bs + K}$$

The frequency response data for the system are given in the following table.

$\omega$ in rad/s	$ G(j\omega) $ in dB	$\arg(G(j\omega))$ in deg
0.01	-18.5	-0.2
0.1	-18.5	-1.3
0.2	-18.4	-2.6
1	-16	-16.9
2	-11.4	-89.4
3	-21.5	-151
5	-32.8	-167
10	-45.3	-174.5

The unit step response of the system approaches a steady state value of \_\_\_\_\_.

Correct Answer :

0.10 to 0.13

Question Number : 59 Question Type : MCQ

A zero mean white Gaussian noise having power spectral density  $\frac{N_0}{2}$  is passed through an LTI filter whose impulse response  $h(t)$  is shown in the figure. The variance of the filtered noise at  $t = 4$  is

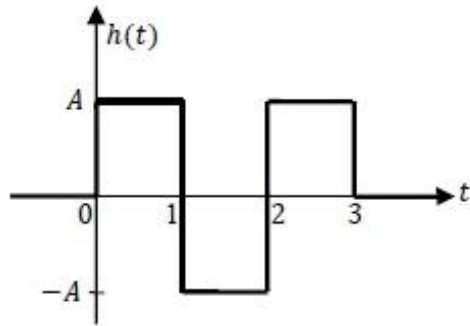

(A)  $\frac{3}{2}A^2N_0$

(B)  $\frac{3}{4}A^2N_0$

(C)  $A^2N_0$

(D)  $\frac{1}{2}A^2N_0$

Options :

1. ✓ A

2. ✗ B

3. ✗ C

4. ✗ D

Question Number : 60 Question Type : MCQ

$\{X_n\}_{n=-\infty}^{\infty}$  is an independent and identically distributed (i.i.d.) random process with  $X_n$  equally likely to be  $+1$  or  $-1$ .  $\{Y_n\}_{n=-\infty}^{\infty}$  is another random process obtained as  $Y_n = X_n + 0.5 X_{n-1}$ . The autocorrelation function of  $\{Y_n\}_{n=-\infty}^{\infty}$ , denoted by  $R_Y[k]$ , is

(A)

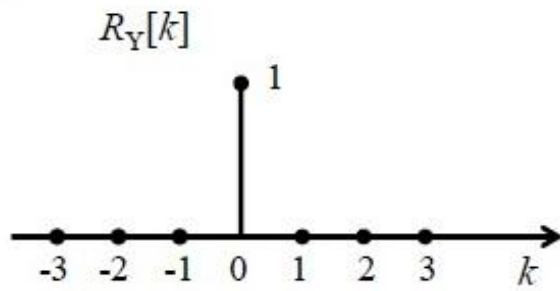

(B)

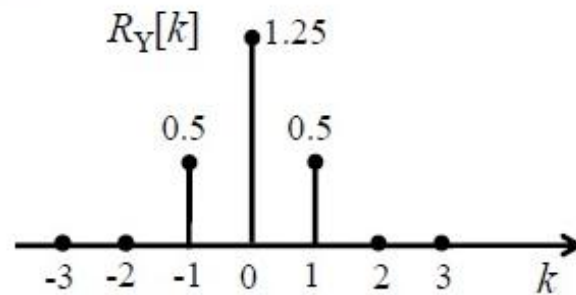

(C)

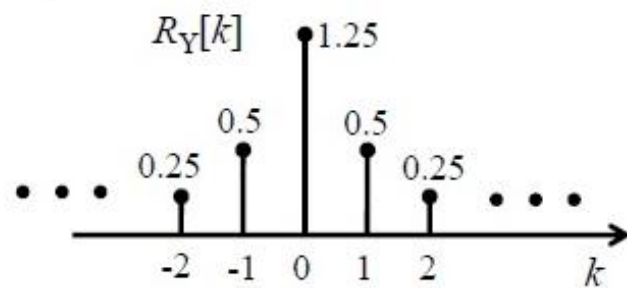

(D)

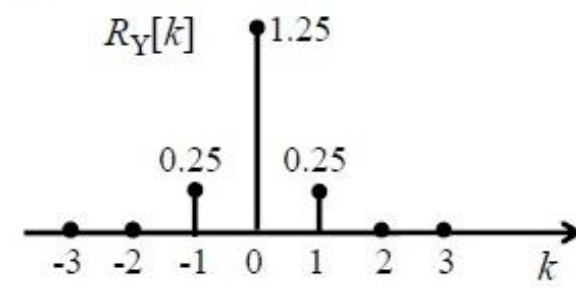

Options :

1. ✘ A
2. ✔ B
3. ✘ C
4. ✘ D

Question Number : 61 Question Type : MCQ



Consider a binary, digital communication system which uses pulses  $g(t)$  and  $-g(t)$  for transmitting bits over an AWGN channel. If the receiver uses a matched filter, which one of the following pulses will give the minimum probability of bit error?

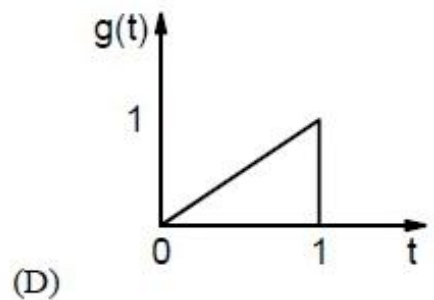
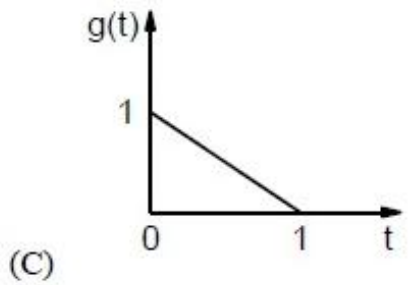
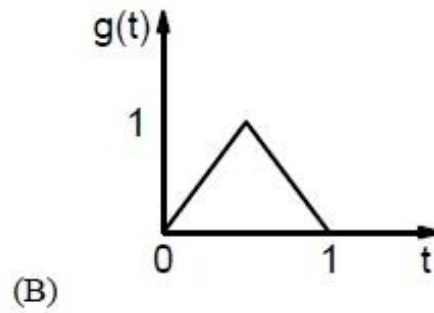
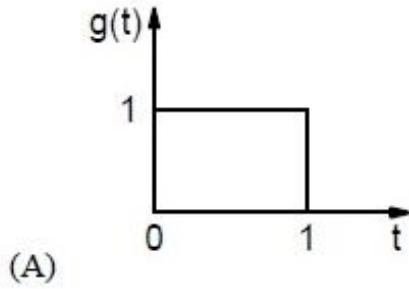

Options :

1. ✓ A
2. ✗ B
3. ✗ C
4. ✗ D

Question Number : 62 Question Type : MCQ

Let  $X \in \{0,1\}$  and  $Y \in \{0,1\}$  be two independent binary random variables. If  $P(X = 0) = p$  and  $P(Y = 0) = q$ , then  $P(X + Y \geq 1)$  is equal to

- |                           |              |
|---------------------------|--------------|
| (A) $pq + (1 - p)(1 - q)$ | (B) $pq$     |
| (C) $p(1 - q)$            | (D) $1 - pq$ |

Options :

1. ✗ A
2. ✗ B
3. ✗ C
4. ✓ D

Question Number : 63 Question Type : NAT

An air-filled rectangular waveguide of internal dimensions  $a$  cm  $\times$   $b$  cm ( $a > b$ ) has a cutoff frequency of 6 GHz for the dominant  $TE_{10}$  mode. For the same waveguide, if the cutoff frequency of the  $TM_{11}$  mode is 15 GHz, the cutoff frequency of the  $TE_{01}$  mode in GHz is \_\_\_\_\_.

Correct Answer:

13.5 to 13.8

Question Number : 64 Question Type : NAT

Two half-wave dipole antennas placed as shown in the figure are excited with sinusoidally varying currents of frequency 3 MHz and phase shift of  $\pi/2$  between them (the element at the origin leads in phase). If the maximum radiated E-field at the point P in the  $x$ - $y$  plane occurs at an azimuthal angle of  $60^\circ$ , the distance  $d$  (in meters) between the antennas is \_\_\_\_\_.

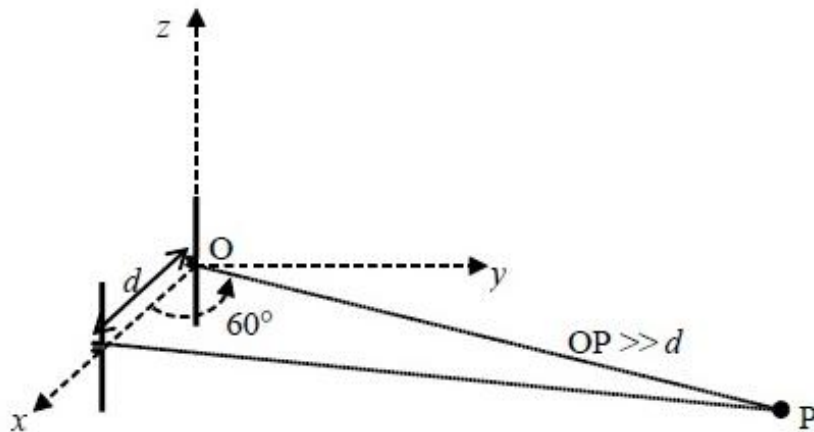

Correct Answer:

49 to 51

Question Number : 65 Question Type : MCQ

The electric field of a plane wave propagating in a lossless non-magnetic medium is given by the following expression

$$\mathbf{E}(z, t) = \mathbf{a}_x 5 \cos(2\pi \times 10^9 t + \beta z) + \mathbf{a}_y 3 \cos\left(2\pi \times 10^9 t + \beta z - \frac{\pi}{2}\right)$$

The type of the polarization is

- (A) Right Hand Circular. (B) Left Hand Elliptical.  
(C) Right Hand Elliptical. (D) Linear.

Options :

1. ✘ A  
2. ✔ B  
3. ✘ C  
4. ✘ D